

INDUSTRIAL SEWAGE WATER QUALITY MONITORING SYSTEM

^[1]AKILA. U, ^[2]ELACKIASSELVI. R, ^[3]MAHESHWARI. R, ^[4]SHUNMUGAVALLI. K UG STUDENTS,

^[5]Mrs.T.PRATHIBA, M.E.,Ph.D AP/ECE

KAMARAJ COLLEGE OF ENGINEERING AND TECHNOLOGY, VIRUDHUNAGAR.

prathibaece@kcetvnr.org,

Abstract— The objective of this project is to develop an automatic wireless system to intimate the message to concerned authority when the waste water from industries are mixed with river illegally. Water pollution is a serious problem for the entire world. It threatens the health and well-being of humans, plants, and animals. The main factor of the water pollution is industries which disposes waste water to the river illegally. In early project, the water pollution was detected by chemical test or laboratory test by using this system the testing equipment will be in stationary and samples will be given to testing equipment. In our project the testing equipment can be placed in the river. The parameters involved in the water quality determination such as the pH level, turbidity, dissolved oxygen and Temperature.

In the Proposed water quality monitoring system the pH and Temperature sensors will be kept in the river. The output of all the sensors are in analog. It is important to convert into digital value. So all the sensed value from the sensor will be given to the ARDUINO board. After converting, the values are compared to the threshold value. In case inference value above threshold value, the automated warning SMS alert will be sent to the Pollution Control Board via GSM.

Keywords— ARDUINO UNO R3, TEMPERATURE SENSOR, pH SENSOR, GSM SIM 300, LCD,MOBILE PHONE.

INTRODUCTION

Water pollution occurs when pollutants are discharged directly or indirectly into water bodies without adequate treatment to remove harmful compounds. Water pollution affects plants and organisms living in these bodies of water. In almost all cases the effect is damaging not only to individual species and populations, but also to the natural communities. Water covers over 70% of the earth's surface and is a very important resource for people and the environment. Water pollution affects drinking water, rivers, lakes and oceans all over the world. Mainly industry sewage water mixed with river. This consequently harms human health and the natural environment. An estimated 1,000 Indian children die of diarrheal sickness every day. Our water resources are prone to a threat of pollution especially from the industrial activities. It is a challenge in the enforcement aspect as it is impossible for the authorities to continuously monitor the location of water resources due to limitation especially in man power, facilities and cost of equipment. The automatic monitoring system will reduce the reliance on man power at the monitoring site thus reducing the cost. This project automatically measure various water pollution parameter using sensor. The output from these sensors is fed to ARDUINO microcontroller. The microcontroller reads the data and then displays in LCD. If the water is polluted the message will be sent to the pollution control board via GSM.

Block Diagram

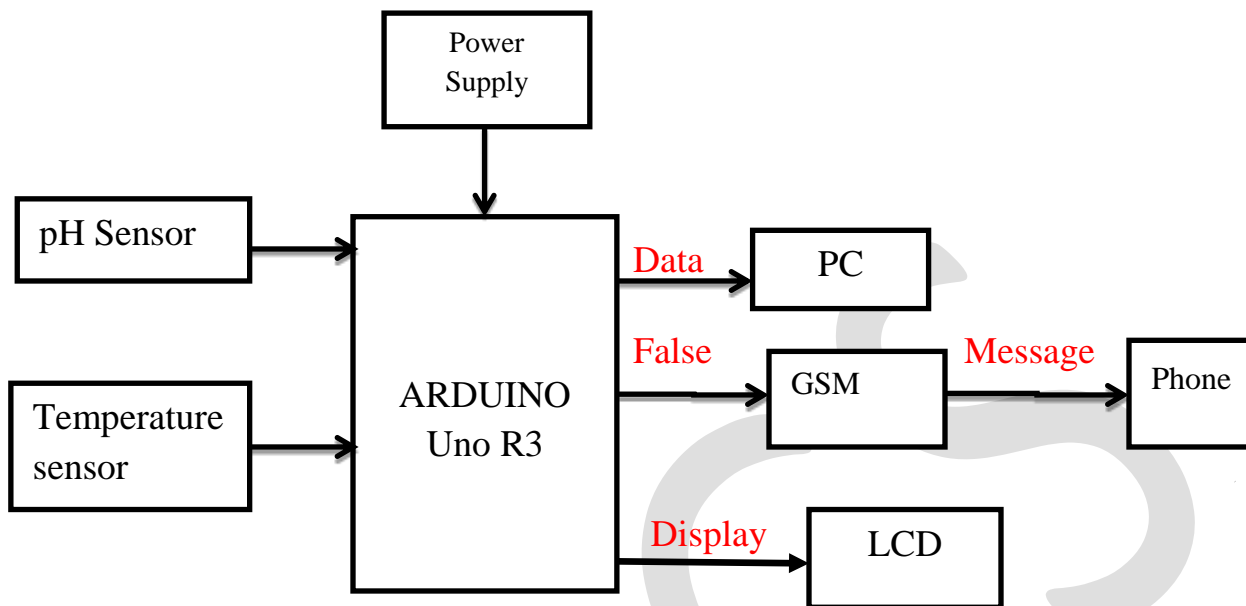

Block diagram of the entire system

The block diagram of our entire system consists of two modules.

The modules are,

- Sensing module
- Receiving module

Sensing Module

Sensing module consists of pH sensor and Temperature sensor. Each sensor sense the data and the data is given to the ARDUINO board.



pH SENSOR

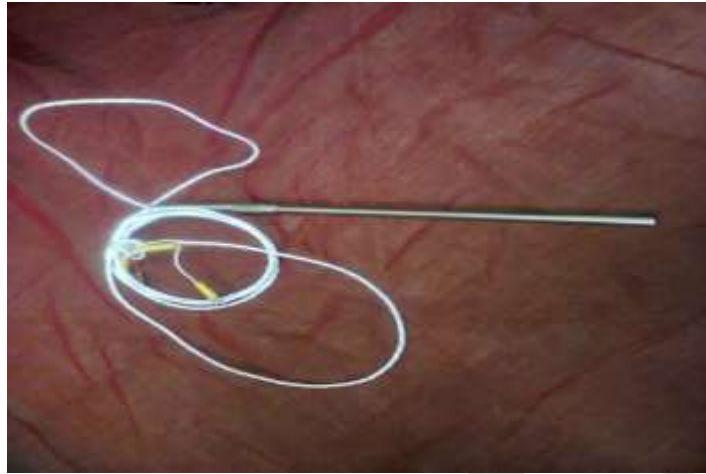

TEMPERATURE SENSOR

Receiving module

Receiving module consists of GSM and Mobile phone.

The data from the ARDUINO board is given to the GSM. If the system detects the water is polluted the message will send to the Pollution Control Board. We use cool term software to store database for Temperature and pH sensor values.



GSM SIM300

Proposed methodology

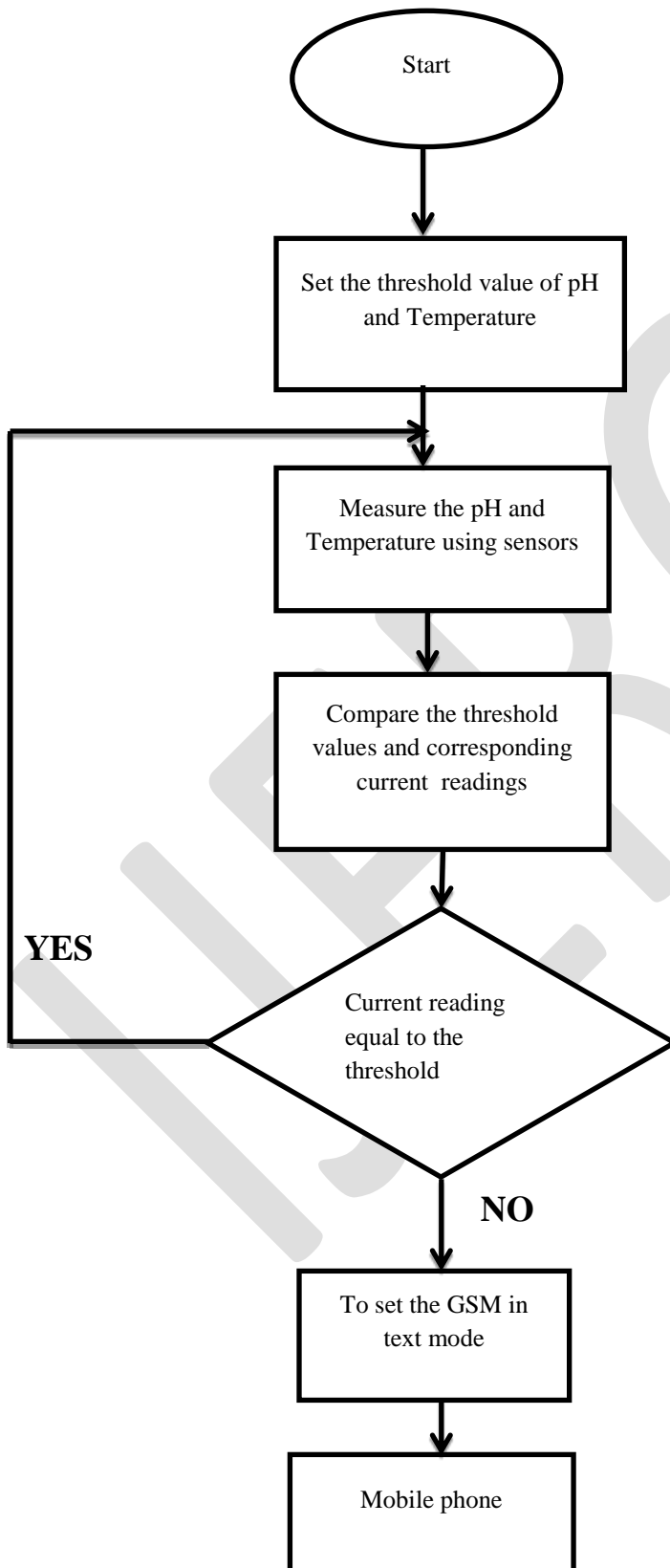

pH sensor

pH measurement reveals the hydrogen ion concentration in water. It is used to determine both the pH value of a water. The most widely used type of pH measurement is the electrode method. pH sensor is used for measuring the pH value. In the process world, pH is an important parameter to be measured and controlled. The pH of a solution indicates how acidic or basic (alkaline) it is. The pH term translates the values of the hydrogen ion concentration- which ordinarily ranges between about 1 and 10×10^{-14} gram-equivalents per litre - into numbers between 0 and 14. The output of the pH sensor can be amplified using instrumentation amplifier.

Temperature sensor

Resistance Temperature detectors (RTD) accurately sense Temperature with an excellent degree of repeatability and interchangeability of elements. The RTD is composed of certain metallic elements, whose change in resistance is a function of Temperature. In operation, a small excitation current is passed across the element and the voltage which is proportional to resistance is then measured and converted to units of Temperature calibration. The RTD element is manufactured by winding a wire or plating a film on a ceramic or glass core and sealing the element within a ceramic or glass capsule. Since most RTDs have a low initial resistance often 100 ohms and have a small change in resistance per unit of Temperature range the resistance of the lead wire is often compensated for with a three or four wire bridge configuration built into the measuring devices. By selecting the proper elements and protective sheathing, RTDs can operate in a Temperature range of $(-200$ to $650)^{\circ}\text{C}$. RTD output is not directly given to the ARDUINO because it accepts only 5V. For enabling the RTD we using voltage divider circuit.

GSM

GSM Modem is simple to interface. Use it to send SMS, make and receive calls, and do other GSM operations by controlling it through simple AT commands from micro controllers and computers. It uses the highly popular SIM300 module for all its operations. It comes with a standard RS232 interface which can be used to easily interface the modem to micro controllers and computers. The modem consists of all the required external circuitry required to start experimenting with the SIM300 module like the power regulation, external antenna, SIM Holder, etc.



INTEFACING WITH ARDUINO

In this experiment, we deployed samples to monitor the pH value and voltage by digital pH monitor. During this experiment, the temperature was between 24⁰Cand 27⁰C.then the graph is plotted between voltage and pH value for further calibration. It is compared with the plot of our ph probe's graph is plotted between pH value and voltage are calculated by multi meter.

SAMPLES AND pH VALUE

SOLUTION	pH VALUE PER 100ml	VOLTAGE (V)
Sample 1	4	3.52
Sample 2	6.2	3.94
Sample 3	7	4.16
Sample 4	9.2	4.52

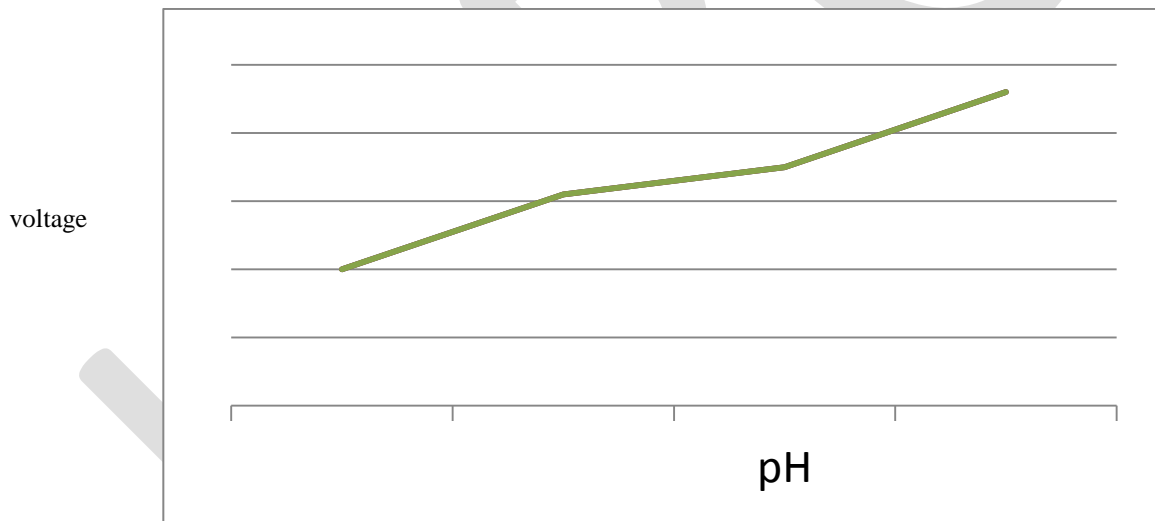

GRAPH BETWEEN pH AND VOLTAGE

In our project we use RTD (RESISTANCE TEMPERATURE DETECTOR) temperature sensor which has resistor that changes resistance value as its temperature changes. By using this resistance value, convert it into voltage for getting original temperature. but the out put of RTD is very high so we use voltage divider circuit for reducing it in to needed value.

The GSM is operated through ARDUINO software for sending message about the quality of water to the concerned authority whose mobile number is specified in the program. In program the threshold value is assigned for pH and temperature sensor (i.e.) 7 for pH and 36⁰C for temperature. The pH value equal to 7 and the temperature less than 36⁰C is considered as pure water. If any one of the conditions is false is assumed to be polluted water then the message is sent to concerned authority via GSM.



MESSAGE DISPLAY ON SCREEN

ACKNOWLEDGMENT

We wish to express our deep sense of gratitude to our Project Guide, **Mrs.T.Prathiba,M.E.,[PhD]**, Assistant Professor, Department of Electronics and Communication Engineering, Kamaraj College of Engineering and technology, Virudhunagar for her guidance and constant supervision as well as for providing necessary information regarding the project and also for her support in completing the project.

CONCLUSION

In this paper, a water quality monitoring system based on wireless sensor network is presented. The system is constituted by a base station and several sensor nodes. In the node side, water quality data is collected by different sensors such as pH and Temperature. If the water is polluted then the data is sent to the concerned authority via GSM.

REFERENCES:

- [1] R.Balaji, R.Ganesan 'Remote water pollution monitoring system using GSM', in International journal of engineering and technology,2012.
- [2] Zulhani Rasin, Mohd Rizal Abdullah 'water quality monitoring system using zigbee based wireless sensor network', in International journal of engineering and technology, IJET-IJENS Vol:09 No:10,December 2009.
- [3] A. C. Khetre & S. G. Hate 'Design and Implementation Of Water environment Monitoring System Based On WSN And GSM Technology' in International Journal of Electronics and Communication Engineering (IJECE), Vol. 2, Issue 3, July 2013.
- [4] Dong He,Li-Xin Zhang 'The water quality monitoring system based on WSN' in Institute of electrical and electronics engineers,2012.

- [5] Theofanis P. Lambrou, Christos C. Anastasiou, Christos G.Panayiotou, and Marios M. Polycarpou 'A Low-Cost Sensor Network for Real-Time Monitoring and Contamination Detection in Drinking Water Distribution Systems' in International journal of engineering and technology sensors journal,VOL.14,NO.8,AUGEST 2014.
- [6] Ruan Yue, Tang Ying 'A water quality monitoring system based on wireless sensor network & solar power supply' in IEEE International Conference on Cyber Technology in Automation, Control, and intelligent Systems March 20-23, 2011.
- [7] Muhammad Azwan Nasirudin, Umami Nurulhaiza Za'bah & O.Sidek 'Fresh Water Real-Time Monitoring System Based on Wireless Sensor Network and GSM' in IEEE Conference on Open Systems (ICOS2011), September 25 – 28, 2011
- [8] K.A.Unnikrishna Menon, Divya , Maneesha V. Ramesh 'Wireless Sensor Network for River Water Quality Monitoring in India' in IEEE July 26 - 28, 2012.
- [9] John Cleary, C. Slater, F. Regan, D.Diamond, 'A wireless sensor network for water quality monitoring' in IEEE Conference on Local Computer Network,2007.
- [10] Kulkarni Amruta M, Turkane Satish.M ' Solar Powered Water Quality Monitoring system using wireless Sensor Network' in IEEE 2013.