

Induction Motor Speed Control Using Android Application

Trupti S Bobade¹, Anushri S. sastikar³, Anushri S. Garud³, U. W. Kaware⁴, R. K. Dehankar⁵

¹Department of electronics and telecommunication, J.D.I.E.T.Yavatmal, India

²Department of electronics and telecommunication, J.D.I.E.T.Yavatmal, India

³Department of electronics and telecommunication, J.D.I.E.T.Yavatmal, India

⁴Assistant professor of Department of electronics and telecommunication, J.D.I.E.T.Yavatmal, India

⁵Assistant professor of Department of electronics and telecommunication, J.D.I.E.T.Yavatmal, India

Abstract - “Android” the world’s most popular mobile platform which is tool for creating application that look great and take advantage of hardware capabilities. The advantage of android is that it is an open source operating system is used in terms of mobile application that is smart phone which will act as a remote controller. Here the proposed system is designed to controlling the speed of induction motor using android application where the remotely controlling speed of induction motor is achieved.

Android mobile act as a transmitter and the received by Bluetooth receiver interfaced to AVR microcontroller of 8051 family. AVR is an advanced version of 8051 microcontroller. Each time data is sent by android application as per code written is executed by AVR to deliver supply signal to triac through optical isolation. Hence the power to load connected in series with triac is controlled based on received signal and speed control of induction motor is achieved.

Keywords- triac, zero crossing detector, AVR microcontroller, optocoupler

INTRODUCTION

For the improvement of quality product many industrial application requires adjustable speed and constant speed. Due to rapid advance in automation and process control the field of adjustable speed drives continuously. In recent technology, various alternate techniques are available for the selection of speed of drive system. Up to the 1980’s the dc motor was the choice for variable speed drive application. Induction motors are using any application such as Industrial drives control, automotive control, etc. In past few years there has been a great demand in industry for adjustable speed drives. Fan, pump, Compressors, domestic applications and paper machines etc... In this area DC motor was very popular but having many disadvantages so that microcontroller transformed research and development toward control of ac drive [1].

When the three phase supply is not available for domestic and commercial application, there we are using single phase induction motor which is one of the most widely used type of low power motor in the world An induction or asynchronous motor is a type of AC motor where power is supplied to the rotor by means of electromagnetic induction, rather than by slip rings and commutator as in slip-ring AC motors. It has a squirrel-cage rotor identical to a single phase and 3-phase motor winding on the stator. There are various methods for controlling the speed of AC motors [1]. There are several of method is available for speed control of ac motor one of the method is two vary frequency and voltage of motor. Speed modulation of a single-phase motor is usually achieved either by some electrical means, such as reducing supply voltage by auto-transformer, or by switching windings to change the number of motor poles for different operating condition as required.

For changing the speed of capacitor run motor as shown in fig.1 voltage control is best method, but it allows only limited speed range to be obtained. Now frequency acts as interesting alternative to voltage control.

The most appropriator actuators for variable speed drive is seem to be capacitor run drive. In our project the speed of induction motor, control with the help of android apps that comes under wireless technology. Android application use here as a transmitter and remote control in order control the speed of induction motor with the help of Bluetooth as a receiver.

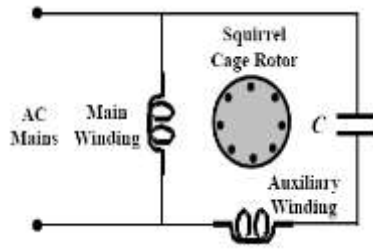

Figure1: Capacitor run single phase induction motor

SYSTEM ARCHITECTURE

In this project, the hardware and software function are combined to make the system reliable. Figure 2 shows the block diagram representation of the systems to be designed and implemented. The Block diagram consists of: Microcontroller, LCD Display, Bluetooth module, Switching assembly, Power supply, Load (either ac motor or bulb), Android application

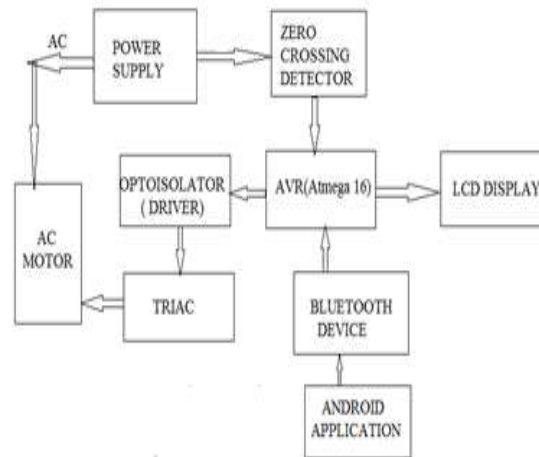

Figure 2: Block Diagram

BLOCK DIAGRAM DESCRIPTION

Microcontroller is the heart of the system. We have used Atmega16 microcontroller in this project. It is getting a 5V power supply from transformer. It is also interfaced with the 16x2 LCD Display, Bluetooth module, optoisolator, triac & induction motor [3].

Atmega16 is high-performance, low-power 8-bit Microcontroller provided by ATMEL AVR. It is having a modified Harvard architecture. Power supply is provided through microcontroller. The atmega 16 that is microcontroller will be interfacing with the Bluetooth module that will act as transmitter for the microcontroller and it will act as receiver to the android application. The necessary data to control the speed of induction motor will be provided to the controller and with the help of android application remotely controlling speed of induction motor is achieved. The optoisolator is used to drive the triac which provides complete pulse to the motor in order to rotate and to control the speed of inductor motor via android application.

WORKING

As shown in above figure transformer T1 step downs 230 V AC into 9 V AC and this is given to bridge rectifier. This rectified output is directly fed to base of Q1 through resistors R1 & R2. Same rectified output is filtered through C1 and given to voltage regulator IC 7805. Output of 7805 is regulated 5 VDC that is given as biasing voltage for both transistors Q1 & Q2 (same regulated 5 V supply is given to main control section also). Both transistors are connected in switch configuration. The final output 'C' is given to main control section.

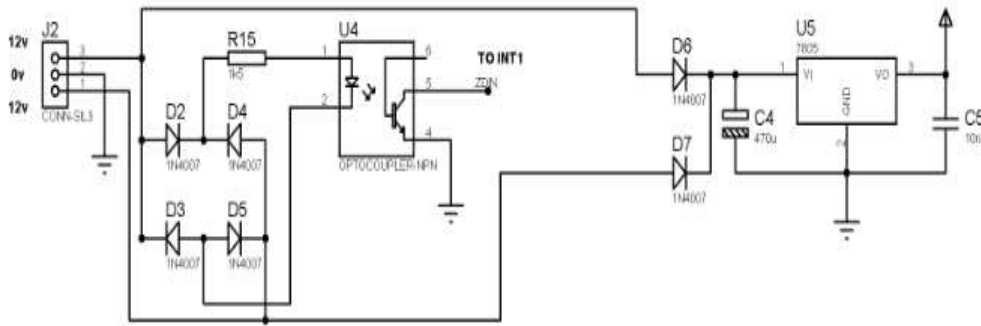

Figure 3: zero crossing detector

As shown in below figure micro controller ATmega16 along with opto-coupler MOC3011 (for triggering TRIAC) and common Anode type bar graph display (for indicating angle) are used for changing firing angle of TRIAC. Signal 'C' from zero crossing detector circuit is directly given to pin no 13 (INT1) that is external interrupt 1 (PD.3) pin. All port PA pins are connected with cathode of bar graph display. It is used to show the status of the motor power and zero cross circuit.

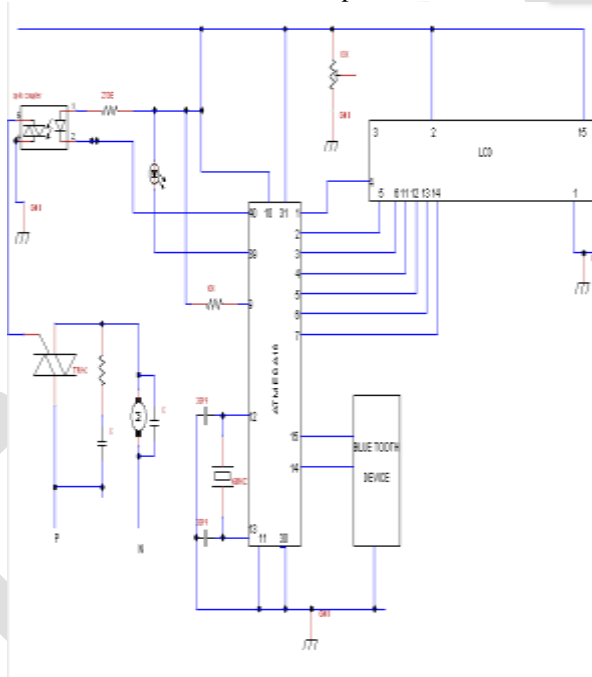

Figure 4: Basic circuit diagram

PD.7 is connected with input of opto-coupler MOC3011. Output of MOC3011 is connected with gate of TRIAC. TRIAC is connected in loop with AC motor and 230 VAC supply as shown. RC snubber circuit is connected in parallel with TRIAC. A 16MHz crystal along with two 22pf capacitor is connected with crystal input pins. Capacitor C2 with Resistor R6 performs power on reset.

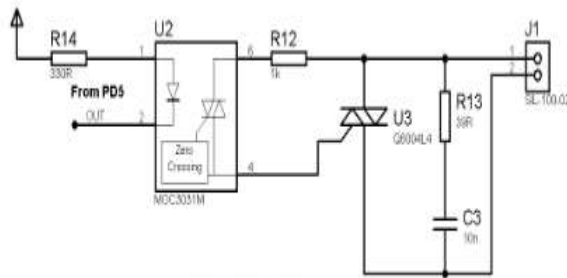

Figure 5: firing angle circuit

APPLICATIONS

1. In home automation application, convinced of remotely controlling the speed of fan is achieved.
2. Many industrial applications require adjustable speed and constant speed for improvement of quality product.
3. Intensity of light can also be controlled with the help of android application.
4. Bell drive application like small conveyors, large blowers, pumps as well as many direct drive or geared application.
5. Wood working machinery air compressors, high processors, water pumps, vaccum pump and high torque application.

ADVANTAGES

1. Remote operation is achieved by any smart-phone /tablet etc. With android os.
2. Technically expert controller is not required.
3. Android app is an open source system to develop any programming code.
4. Programming code is not always required to change for different input parameters.
5. Bluetooth consumes less power so more preferable.
6. More useful for the patient and disabled person.

DISADVANTAGES

1. It is of short range as we are using Bluetooth as transmitter.
2. Android app we are using consumes more battery of users phone.
3. High complexity i.e. device and application impact.

CONCLUSION

The objective of a project has been achieved which has been developing the hardware and software for controlling speed of induction motor using android application. The demand for wireless operating device increases, it is more preferable over wired devices. Here we are controlling speed of induction motor using Bluetooth and android application wirelessly.

FUTURE SCOPE

The future scope will be controlling the speed of three phase induction motor likewise that of the single phase induction motor using android application. Also we can use GSM module instead of Bluetooth technology to control the speed of induction motor. The speed can also be controlled automatically using temperature sensor LM 35.

REFERENCES:

- [1] Rakesh Parekh (2003). AC Induction Motor Fundamentals. Microchip Technology Inc.
- [2] Muhammad H. Rashid: "Power Electronics Circuits, Devices & Application" PHI, New Delhi, 2001.
- [3] Salivahanan, S.Suresh, N., and Vallavaraj, A. "Electronic Devices and Circuit", Fourth Edition, Tada Seventh Edition, 2000, McGraw-Hill Publishing Company Limited.
- [4] Bayindir R., Sefa İ., "Novel approach based on microcontroller to online protection of induction motors", *Energy Conversion and Management*, 48 (3): 850-856, (March 2007).
- [5] Zero Crossing Detectors by SUNPLUS.
- [6] Petermutschler Darmstadt University Of Technology Department Of Power Electronics And Drives: A New Speed Control Method For Induction Motors
- [7] Atul M.Gajare Nitin R.Bhasme A Review On Speed Control Techniques Of Single Phase Induction Motors, ISSN 2249-6343, International Journal Of Computer Technology And Electronics Engineering, Volume 2, Issue 5, October 2012
- [8] *Stephen L. Herman, electric Motor Control, 9th edition.*
- [9] J. Zhang, "Single phase input cycloconverters driving an induction motor" Ph.D. thesis, University of Technology, Sydney.
- [10] Modern Applied Science Vol 5, No 3 (2011). A Novel Approach to Analog Signal Isolation through Digital Opto-coupler (YOUTAB)
- [11] Agilent Technologies Introduces Industry's Fastest Optocouplers. Business Wire. December 2, 2002.
- [12] Safety Considerations When Using Optocouplers and Alternative Isolators for Providing Protection Against Electrical Hazards. January 2010. Retrieved November 5, 2010.
- [13] M.D. Singh, K.B. Khanchandani, Power Electronics, Second Edition, Tata McGraw-Hill, New Delhi, 2007, pages 148-152.

- [14] "Philips Semiconductors Product specification Triacs BT138 series". 090119 nxp.com
- [15] www.bluetooth.com
- [16] www.palowireless.com
- [17] *Johansson and Gerla's Bluetooth Tutorial at Mobicom 2001.*
- [18] Discovering Bluetooth by Brent A. Miller.
- [19] <http://en.wikipedia.org/wiki/Bluetooth>
- [20] <http://www.bluetooth.com/bluetooth>

IJERGS