

Design Of Abrasive Jet Machine

Harshavardhan Ronge, Swapnil Wagh, Rohit Shinde

Department of Mechanical Engineering

Walchand College of Engineering, Sangli,

E-mail- harsh.ronge@gmail.com, Contact-8390825000

Abstract: In abrasive jet machine, abrasive particles with high velocity are impacted on workpiece. Work material is removed by erosion action. High velocity of particles, proper mixing of air and abrasive particles are important factors for good working of abrasive jet machine. Considering this, we have made design of mixing part of abrasive jet machine. This design uses pressurized abrasive feed. This pressurized abrasive powder is then mixed with high pressure air. Pressure is obtained in both uses from same pressure supply. Abrasive flow is designed to be controlled by pinch of valve. All design calculations and methodology used is given further in paper.

Keywords- Abrasive jet machine, Design, CAD, Mixing chamber, Pinch valve, Hoop stress, Pressure

INTRODUCTION:

Abrasive jet machining (AJM) is a processing nontraditional machine which operates materials without producing shock and heat. AJM is applied for many purposes like drilling, cutting, cleaning, and etching operation. In Abrasive jet machining abrasive particles are made to impinge on the work material at high velocity. A jet of abrasive particles is carried by carrier gas or air. The high velocity stream of abrasives is generated by converting the pressure energy of carrier gas or air to its Kinetic energy and hence the high velocity jet. Nozzles direct abrasive jet in a controlled manner onto work material. The high velocity abrasive particles remove the material by micro-cutting action as well as brittle fracture of the work material. Machining, Drilling, Surface Finishing are the Major Processes that can be performed efficiently. The process parameters are used like variables which effect metal removal. They are carrier gas, abrasive, and velocity of abrasive, work material, and nozzle tip distance (NTD). Abrasive jet cutting is used in the cutting of materials as diverse as: Titanium, Brass, Aluminum, Stone, Any Steel, Glass, Composites etc.

Conceptual design-

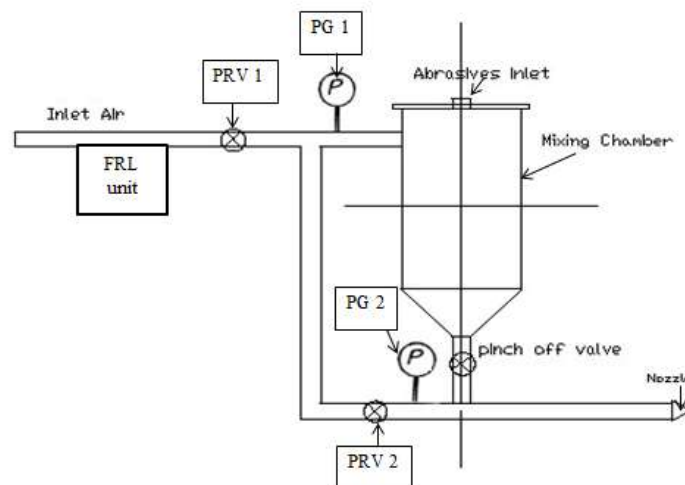

Fig.1 Conceptual design of AJM

Basic Components:

1. Abrasive Reservoir
2. Pinch-off valve

3. Pressure regulating valves
4. Pressure gauge
5. Nozzle
6. Air supply Line
7. Air abrasive mixture line

Description:

The compressed air is fed through the inlet line, the pressurized air contains moisture which need to removed hence FRL unit is introduced at the inlet pressure line. The pressure of air is regulated using pressure regulating valve. This air is then supplied to the abrasive reservoir, another line of air is connected to the outlet of abrasive reservoir via pressure regulating valve. Pressure at the inlet of the abrasive reservoir is maintained at higher pressure with the help of PRV1 than that of the pressure in PRV2 .If this provision was not made then the air will bubble into the abrasive reservoir through pinch-off valve. The flow of abrasive particle is regulated using pinch-off valve, it is provided at the bottom of abrasive reservoir. Pinch-off valve is connected to the conical section of abrasive reservoir using pipe. The pinch-off valve consists of abrasion resistance sleeve whose cross section can be changed by movable plates. The plates slides up and own and is supported by two rods. Their movement is controlled by rotating the valve .Hence the mass flow of abrasive can be controlled in order to control the abrasive air ratio which is an important process parameter. The mixture of air and abrasive formed at the outlet of pinch-off valve is then passed through a nozzle.

Initially the on-off valve is set in open position, this let the air pass to the abrasive chamber and the pressure line. When the required pressure is met in the abrasive reservoir the pinch-off valve can then be gradually opened to admit the abrasive particle in the air. The ratio of mass of air to abrasive particle needs to be maintained at an optimum level. This can be done during experimentation. In the pinch-off valve there is no direct contact between the metal and abrasive particle, there is no wear of valve and have a good service life. But the sleeves need to be replaced though they are abrasion resistant, its service life is less and needs replacement. The air and abrasive particles gets mixed at the T-section and as they pass through the pipe. The limitation of intermittent flow of abrasive particle is eliminated by introducing the pinch off valve. The air imparts the kinetic energy to the abrasive particle during their flow through pipe, initially their kinetic energy is low but as they pass through the nozzle, its kinetic energy increases in accordance to Bernoulli's principle. In order to stop the machining, the on-off valve is set to off position and then the pinch-off valve is closed. If pinch-off is first closed and then the valve set to off-position, then there is a possibility of irregular machining, since the pinch-off valve can't be closed in spit second. Also during closing the pinch off valve, the abrasive mass flow decreases gradually and may affect the surface finish of work piece. Hence considering the current capability of the system and its limitation, most of its limitations can be overcome by the new mixing chamber.

Design calculations for abrasive feeder

Abrasive feeder is a pressure vessel, because we want to maintain pressure around 10 bar. But for design we take pressure as 15bar for design calculation. Mixing chamber will have two portions- cylindrical and conical. Conical portion is to facilitate easy flow of abrasive particles and all abrasive particles will slide down.

We chose to construct cylindrical portion by using steel tubes in market. We searched for catalogue of steel tubes and took data for design calculation. Storing capacity of abrasive feeder should be 2 kg of silicon carbide abrasive particles.

Calculation for volume of cylindrical portion:

Density of abrasive particles is 1.3 gm/cc.

Assuming whole 2 kg is stored in cylindrical portion. Cone volume will provide additional storage capacity,

$$\text{Volume of cylinder} = \text{mass of abrasive particles} / \text{density}$$
$$\frac{\pi}{4} D^2 L = \frac{2000 \text{ gm}}{1.3 \text{ gm/cc}}$$

$$\frac{\pi}{4} D^2 L = 1538$$

Available diameter and thickness values of steel tube are taken from catalogue.

Stress calculation for steel tubes with 15 bar pressure and available dimensions.

$$\sigma(\text{hoop}) = \frac{PD_{avg}}{2t}$$
$$\sigma(\text{longitudinal}) = \frac{PD_{avg}}{4t}$$
$$\sigma(\text{hoop}) > \sigma(\text{longitudinal})$$

Therefore, $\sigma(\text{hoop})$ will be considered for calculation.

$$t = \frac{PD}{2\sigma - P}$$

Where, P = Internal pressure,

D = Internal diameter of cylinder

J = Joint efficiency = 1

All calculation is done in excel. Results show that maximum stress generated in all dimensions is 33.48 MPa . While minimum strength available in catalogue is 210 MPa . Thus it is safe design for any available dimension in catalogue.

Table 1 selection of diameter and length

Outer dia.	t	Avg. dia.	Stress	Length
Mm	mm	mm	MPa	Cm
101.6	3.6	98	20.41667	22.00562
101.6	4	97.6	18.3	22.38339
101.6	4.8	96.8	15.125	23.16871
114.3	3.6	110.7	23.0625	17.09616
114.3	4.5	109.8	18.3	17.68564
114.3	5.4	108.9	15.125	18.30614
127	4.5	122.5	20.41667	14.0836
127	4.8	122.2	19.09375	14.22792
127	5.4	121.6	16.88889	14.5233

Table 2 Selection for diamentions of cone

Avg. dia of pipe	t (α=40)	t(α=50)	t(α=60)
Mm	mm	Mm	Mm
98	1.990494	1.985534	1.979798
97.6	1.98237	1.97743	1.971717
96.8	1.966121	1.961221	1.955556
110.7	2.248446	2.242843	2.236364
109.8	2.230166	2.224608	2.218182
108.9	2.211886	2.206374	2.2
122.5	2.488118	2.481917	2.474747
122.2	2.482025	2.475839	2.468687
121.6	2.469838	2.463683	2.456566

Upper side of mixing chamber will be covered by flange. Flange will be attached to main body by bolts.

Calculation for bolt diameter

$$P A(\text{cylinder}) = n \sigma A(\text{bolt})$$

$$P \frac{\pi}{4} D^2 = n \frac{\pi}{4} d^2 \sigma$$

$$P D^2 = n d^2 \sigma$$

where, P = Pressure = 15 bar

D = inside diameter of mixing chamber

n = number of bolts

d = diameter of bolt

σ = stress = 50 MPa

n=4	d= 9.9 mm
n=6	d= 7.31 mm

CAD model

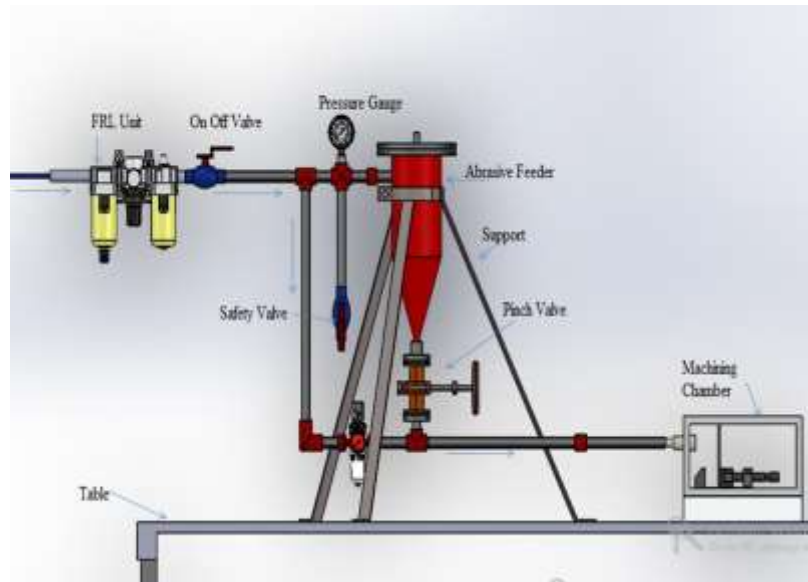

Fig 2 CAD model of design

Conclusion

For optimum performance of machine, the parameters like NTD, pressure of jet, grain size, type of abrasive, nozzle tip size, mixing ratio and abrasive mass flow rate have been studied and analyzed. Depending upon the situation, if material removal rate is improved, stand off distance should be on higher side. On the other hand if precision and better surface finish are requirements, the shorter stand-off distance with higher air pressure is recommended.

REFERENCES:

- [1] Dr.A. k. Paul &R. K. Roy “some studies on Abrasive jet machining the Journal of the Institution of Engineers (India) Vol 68 part PE 2 November 1987
- [2] Dr. M. Sreenevasa Rao, D. V. Shrekanth, “Abrasive jet machining-Research Review”, *International journal of Advanced engineering Technology*, Vol. 5, pp.18-24, April-June. 2014.
- [3] X. P. Li, K. H. W. Seah. “Effect of pressurized air on metal cutting”, *wear* 255, 2003
- [4] Manabu Wakuda, Yukihiro Yamauchi, Shuzo Kanzaki. “Material response to particle impact.” *Journal of Materials Processing Technology* 132,pp. 177–183,2003
- [5] A. Ghobeity, H. Getu, T. Krajac, J. K. Spelt, M. Papini. "Process repeatability in abrasive jet micro-machining". *Journal of materials processing technology* 190(2007), pp.51-60, 2007.
- [6] A. Ghobeity , D. Ciampini, M. Papini. “Effect of particle size distribution on the surface profile”. *Journal of Materials Processing Technology* 209 pp. 6067–6077, 2009
- [7] A. El-Domiati, H. M. Abd El-Hafez and M.A. Shaker. “Drilling of Glass Sheets by Abrasive Jet Machining.” *World Academy of science, Engineering and Technology*, vol.3, pp.57-63, Aug.2009.
- [8] Alireza Moridi, Jun Wang, Yasser M. Ali, Philip Mathew and Xiaoping Li. “Drilling of Glass Sheets by Abrasive Jet Machining.” *Key Engineering Materials*, vol. 443, pp. 645-651, June 2010.

- [9] Mr. Bhaskar Chandra. “A Study of effects of Process Parameters of Abrasive jet machining” *International Journal of Engineering Science and Technology*, vol.3, pp.504-513,Jan. 2011.
- [10]Jukti Prasadn Padhy, “Optimization and effect of controlling parameters on AJM using Taguchi technique”*Int. Journal of Engineering Research and Applications* ISSN : 2248-9622, Vol. 4, Issue 3 (Version 1), pp.598-604, March 2014.
- [11]Process design equipment [3rd edition 1996] by M. V. Joshi and V. V. Mahajan
- [12]Machine design element by V. B. Bhandari

IJERGS