

# Wireless Sensor Network for Driver Assistance and Intelligent Transportation

Yamini B. Pawar\* , Prof. J. R. Panchal\*

Siddhant College of Engineering, Pune (ME VLSI & Embedded Systems)

ME Student , yamini.madhav@yahoo.com, 758805990

**ABSTRACT-** Globalization, Modernization, migration have taken great tolls on road usage. Inadequacy in transportation infrastructures can cripple a nations progress, social well-being, and economy. With fuel price soaring and potential threats of fuel shortage, we are now faced with greater challenges in the field of transportation systems. Electronics technology impacted the construction of cars, embedding them with sensors and advanced electronics, making cars more intelligent, sensitive and safe to drive on. In this project, we will implement a system and examine the impact of future ITS technologies on road safety and emergency services. We will use numerous technologies to assist and manage transportation. We also implement co-operative traffic management involving vehicles , roadside infrastructure and wireless sensor network. Vehicles will carry computing and communication platform and will provide enhanced sensing capabilities. Wireless sensor networks will enhance transportation safety and efficiency by providing driver assistance . A key aspect of Wireless sensor network is to expand the time horizon of information relevant to driving safety and transportation efficiency, but also introduce new information sources, and improve its quality thus providing intelligent transportation. The basis is a collaborative approach, with each vehicle and RSU contributing relevant information, based on their own sensing and on information received from nearby peers and RSUs, vehicles can anticipate, detect, and avoid dangerous or unwanted situations. For example, timely notifications about lane changes, emergency braking, and un- safely approaching vehicles can be highly beneficial. The same is true for notifications about dangerous or heavy traffic conditions disseminated by RSUs, locally or within a larger region with the help of other vehicles.

**Index Terms**—RSUs, V2V, V2I ,VANET, Intelligent transportation, Safety parameters, Wireless Sensor Network

## I. INTRODUCTION

The population of the world has been increasing, road traffic has also been getting more and more congested, as a higher population and increased business activities result in greater demand for cars and vehicles for transportation. With fuel price soaring and potential threats of fuel shortage, we are now faced with greater challenges in the field of transportation systems. Inadequacy in transportation infrastructures can cripple a nations progress, social well-being, and economy. Previously, focused was given on how to build efficient highways and roads. Over time, the focus shifted to mechanical and automotive engineering, in the pursuit of building faster cars to surmount greater distances. Later on, electronics technology impacted the construction of cars, embedding them with sensors and advanced electronics, making cars more intelligent, sensitive and safe to drive on. Now, innovations made so far in wireless mobile communications and networking technologies are starting to impact cars, roads, and highways. This impact will drastically change the way we view transportation systems of the next generation and the way we drive in the future. It will create major economic, social, and global impact through the transformation . In this project, we will implement a system which will enhance efficiency and safety of transportation. Wireless sensor network uses numerous technologies to assist and manage transportation. The basis is a collaborative approach, with each vehicle and RSU contributing relevant information, based on their own sensing and on information received from nearby peers and RSUs, vehicles can detect, and avoid dangerous or unwanted situations.

Wireless transmission and medium access technologies adapted to the VC environment are the primary enabling technology. Conceptually, on top of them, networking technologies allow for data exchange among nearby and remote devices (vehicles, RSUs, and other servers). data concerning the vehicle operation will be obtained via the corresponding or upgraded onboard interfaces. VC computing platforms are to be dedicated to VC functionality.

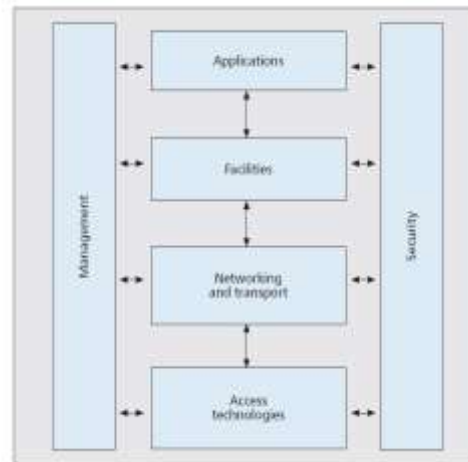

Fig. 1. Common reference architecture for co- operative Vehicular Communication

Cars are already equipped with multiple processors and microcontrollers dedicated to tasks such as fuel injection, braking, transmission, and battery charging; For easy reference, we term these car processors and controllers. The VC computing platform will be functionally independent and responsible for running the vehicle-to-vehicle (V2V) and vehicle-to-infrastructure (V2I) communication protocols and the supported applications. Sensing equipment is already installed onboard. The communication equipment comprises a set of technologies with different characteristics (bit rates, communication range, transmission power, frequency bands). Basically, there is short-range ad hoc communication to enable primarily V2V but also V2I communication, and long-range infrastructure-based communication primarily for V2I purposes. Intelligent Transportation will enable applications in three primary directions: transportation safety, transportation efficiency, and user services delivered to the vehicle. Recent technological developments, notably in mobile computing, wireless communication, and remote sensing are used in Intelligent Transportation. Vehicles are already sophisticated computing systems, with several computers and sensors onboard, each dedicated to one part of the car operation. Wireless communication, computing and sensing capabilities interconnect vehicles not only to collect information about themselves and their environment, but they also exchange this information in real time with other nearby vehicles. Vehicles and infrastructure cooperate to perceive potentially dangerous situations in an extended space and time horizon. Appropriate vehicular communication (VC) architectures are necessary to create reliable and extended driving support systems for road safety and transportation efficiency for Intelligent Transportation. Vehicles will be equipped with novel computing, communication, and sensing capabilities, and user interfaces. These will support numerous applications that enhance transportation safety and efficiency, but also provide new or integrate existing services for drivers and passengers and improve its quality. User-portable devices are also expected to be wirelessly attached to the onboard equipment. The basis is a collaborative approach, with each vehicle and RSU contributing relevant information, based on their own sensing and on information received from nearby peers and RSUs, vehicles can anticipate, detect, and avoid dangerous or unwanted situations. For example, timely notifications about lane changes, unsafely approaching vehicles, safe distance can be highly beneficial. The same is true for notifications about dangerous or heavy traffic conditions disseminated by RSUs, locally or within a larger region with the help of other vehicles. The vast majority of applications fall largely in the above mentioned three categories:

- Data, most often region-specific, about the transportation system and traffic conditions are made available to drivers to enhance transportation efficiency.
- The driver is assisted, in order to enhance transportation safety.
- Services enhance the users like passengers and drivers comfort by providing media download, map download.

Most of the traffic accidents are known to occur when the drivers don't know urgent running condition around him. The driver in the vehicles controls the brake or lane change without right information related to road condition, speed of the nearby vehicle, traffic signals and so on. Wireless communication technology can be considered to provide driving information for safety. A vehicular ad hoc network (VANET) is a communication technology for both vehicle to vehicle (V2V) which is one of the mobile ad-hoc network (MANET) applications and vehicular to infrastructure (V2I).

## II. PROPOSED APPROACH

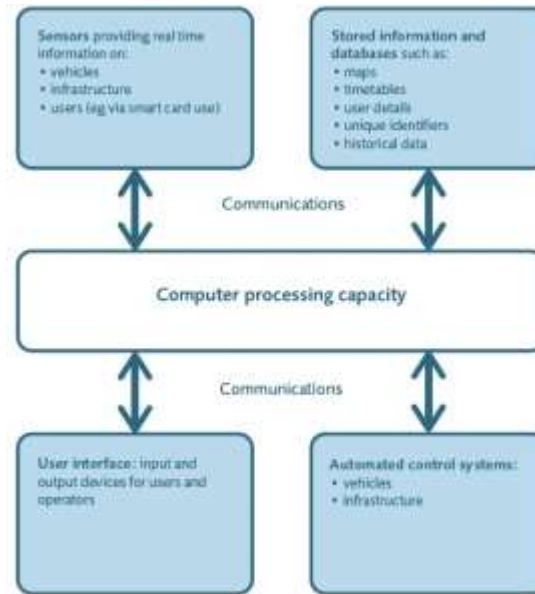

Fig. 2. The Key Components of typical intelligent transportation system

This project covers a wide spectrum, including driver- vehicle interface, preventive road safety, on-board sensors, cooperative systems and cooperative networks, maps and geo- graphical technologies, and vehicle-to-vehicle (V2V) communications. In this paper, we focus on how vehicular communication networks have impacted road safety and how efficiency of transportation will enhance in the future.

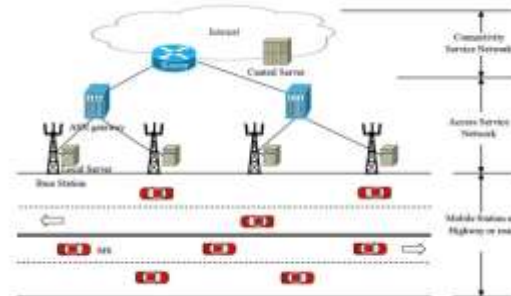

Fig. 3. Proposed System

Intelligent Transport Systems (ITS) comprise several combinations of communication, computer and control technology developed and applied in the domain of transport to improve system performance, transport safety, efficiency, productivity, and level of service, environmental impacts, energy consumption, and mobility.

### III. PARAMETERS TO BE OBSERVED

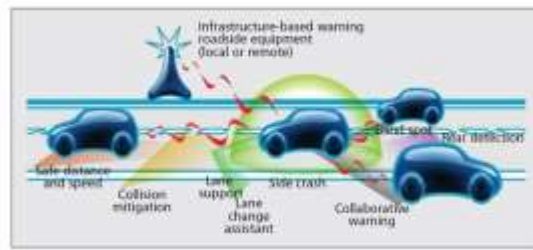

Fig. 4. Safety parameters of Proposed System

- Blind Spot
- Lane Change Warning
- Safe Distance and Speed Control
- Information about Hazardous Locations
- Information about Accident and its location

### IV. FEATURES

The vast majority of applications fall largely in the above- mentioned three categories:

- Data, most often region-specific, about the transportation system and traffic conditions are made available to drivers to enhance transportation efficiency.
- The driver is assisted, in order to enhance transportation safety.
- Services enhance the users like passengers and drivers comfort by providing media download, map download.

ITS are systems that support the driver in her/his task of driving a vehicle in order to increase safety, efficiency and comfort, Detection of situational parameters by sensors .

Sensors: Devices that measure a physical quantity and convert it to a readable signal (e.g. Ultrasonic sensor) Examples: • Electronic Stability Control (ESC) • Adaptive Cruise Control (ACC) • Lane Departure Warning (LDW) Creation of an Information Horizon The right information in the right situation to the driver Extends safety time margin Extends beyond the physical horizon Safety: • Traffic Jam Ahead Warning • Curve Speed Warning • Intersection Assistance • Black Spot Warning Intelligent Transport Systems (ITS) embrace a wide variety of communications-related applications intended to increase travel safety, minimise environmental impact, improve traffic management and maximise the benefits of transportation to both commercial users and the general public. In Cooperative ITS (C-ITS), vehicles communicate with each other and/or with roadside infrastructure, greatly increasing the quality and reliability of information available about the vehicles, their location and the road environment. This will bring major social and economic benefits and lead to greater transport efficiency and increased safety. The essential characteristic of Co-operative-ITS is the sharing of data between different applications both inside the same ITS station and across several ITS stations, where ITS stations are operated as bounded, secured and managed domains.

## V. BLOCK DIAGRAM OF PROPOSED SYSTEM

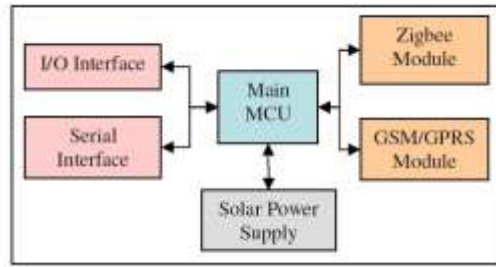

Fig. 5. Block diagram of Proposed System

### A. Block diagram description

- **Microcontroller-** The LPC2148 microcontrollers are based on a 16-bit/32-bit ARM7TDMI-SCPU with real-time emulation and embedded trace support, that combine microcontroller with embedded high speed flash memory ranging from 32 KB to 512 KB.
- **ZigBee** is a specification for a suite of high-level communication protocols used to create personal area networks built from small, low-power digital radios. ZigBee is based on an IEEE 802.15.4 standard. Though its low power consumption limits transmission distances to 10 to 100 meters line-of-sight.
- **A GSM modem-** is a wireless modem that works with a GSM wireless network.
- **Ultrasonic distance measure sensor** -The ultrasonic distance measurer (UDM) is used mainly when a non-contact measurer is required.
- **DC Motor-**It is just require to run the model of proposed system.

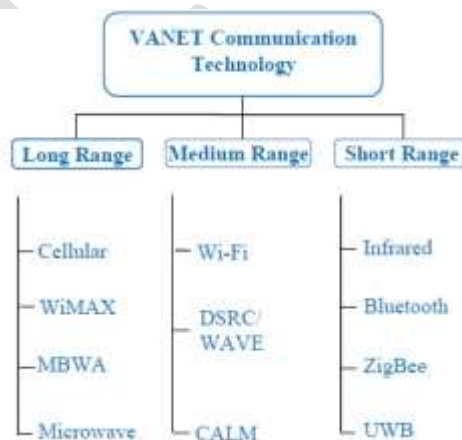

Fig. 6. VANET communication technology signal range wise

## VI. APPLICATIONS

- 1) Travel and Traffic Management • Route guidance • Traffic Control • Incident Management • Pre-trip travel information
- 2) Advanced Vehicle Safety Systems • Intersection collision avoidance • Pre-crash warning • Blind spot detection and avoidance • On-board safety monitoring
- 3) Emergency Management for vehicles

## VII. FUTURE SCOPE

The surveyed recent concerted efforts have yielded significant results and momentum for further developments. Several challenges lie ahead before VC systems can be deployed. 1. Building large-scaled experimentation it is necessary for thorough testing and validation of the system dependability. This includes not only the data link and networking technologies but also the applications themselves, notably those with the most stringent requirements. 2. Ensuring efficient and effective operation even in challenging situations, even if unlikely to occur in practice, is necessary (e.g., as the size of VC networks scales up). 3. The integration of strong and efficient security mechanisms should not be neglected, especially as an architecture and protocols for secure VC along with privacy enhancing technologies are developed. With the appropriate design, secure VC systems can be as effective as non-secure ones. Thus, with the current and growing awareness of the importance of security, trustworthy VC systems could be deployed.

## VIII. CONCLUSION

Future ITS- based emergency services aim to provide safety for users and vehicles as well as significantly improving the response time and efficient use of resources. • Increases travel safety • Minimizes environmental impact • Improves the productivity of existing transportation systems • Improves mobility Thus Intelligent Transportation provides major social and economic benefits and lead to greater transport efficiency and increased safety.

## REFERENCES:

- [1] Adil Mudasir Malla, Ravi Kant Sahu, "A Review on Vehicle to Vehicle Communication Protocols in VANETs", International Journal of Advanced Research in Computer Science and Software engineering, Vol.3, Issue 2, Feb 2013
- [2] Buddhika R. Maitipe, U. Ibrahim, M. I. Hayee, and Eil Kwon, "Vehicle- to- Infrastructure and Vehicle-to-Vehicle Information System in Work Zones Dedicated Short-Range communications", Transportation Research board, 2012
- [3] Francisco J. Martinez, Chai-Keong Toh, Juan-Carlos Cano, Carlos T. Calafate, and Pietro Manzoni "Emergency Services in future Intelligent Transportation Systems based on Vehicular communication networks", IEEE intelligent Transportation system magazine, Vol.5, No.8, Summer 2010
- [4] Haijun Zhao, Yikui Zhang, "The Embedded Application of Wireless Short-Distance Communication Technology in Vehicle Diagnosis process", IEEE International conference on Computer and Information Technology, 2010
- [5] Imane Lhadi, Marwa Rifai, Yassine Salih Alj, "An Energy-Efficient WSN- based Traffic Safety System", 2014 IEEE International conference on Information and Communication Systems
- [6] Intelligent Transport System Technology, "Conversation Paper", Ministry of transport, June 2013
- [7] Kamal Deep Singh, Priyanka Rawat and Jean-Marie Bonnin, "Cognitive radio for vehicular ad hoc networks (CR-VANETs): approaches and challenges", Springer 2014, Journal on Wireless Communication and Networking
- [8] Panos Papadimitratos, EPFL Arnaud de La Fortelle, Mines ParisTech Knut Evensen, Q-Free ASA Roberto Brignolo and Stefano Cosenza, Centro Ricerche FIAT, "Vehicular Communication Systems: Enabling Technologies, Applications, and Future Outlook on Intelligent Transportation", IEEE Communication Magazine, November 2009

- [9] Paul Alexander, David Haley,Alex Grant,” Co-operative Intelligent Trans- port Sys- tems:5.9 GHz Field Trials”, Proceedings of IEEE 2011
- [10] Pavle Belanovic, Danilo Valerio,Alexander Paier, Thomas Zemen,Fabio Ricciato, and Christoph Mecklenbrauker,” On Wireless Links For Vehicle-to-Infrastructure Communications”, IEEE Transactions on Vehicular Technology,2009
- [11] Roger R. Stough and Guang Yang,” Intelligent Transportation Systems”, Transportation Engineering and Planning,Vol.2,No.11,Dec 2010
- [12] M. Shahid Anwer, Chris Guy ,”A Survey of VANET Technologies”,Journal of Emerging Trends in Computing and Information Sciences,Vol.5,No.9,September 2014
- [13] Sang-Eon Kim, Han-Lim Kim, Jong-Sam Jin, Seong-Choon Lee” A new approach for Vehicle Accident Prevention on the highway using Mobile WiMAX” IEEE Transactions on Vehicular Technology, Vol.4, May 2009
- [14] Vicente Milanes,Jorge Villagra,Jorge Godoy, Javier Simo,Joshue Perez Rastelli,Enrique Onieva,” An Intelligent V2I Based Trafic Management System” ,IEEE Transactions on Intelligent Transportation Systems,Vol.13. No.1,March 2012