

## Garlic Peeling Machine – A Past Review

Mohan S.Nimbarte<sup>1</sup>

Department Of Mechanical Engineering, PCE, RTMN  
University  
Nagpur, Maharashtra, India  
mohannimbarte@gmail.com

K.S.Zakiuddin<sup>2</sup>

Department of Mechanical engineering, PCE, RTMN  
University,  
Nagpur, Maharashtra, India  
[qszaki1@rediffmail.com](mailto:qszaki1@rediffmail.com)

**Abstract**—This paper presents the review of garlic peeling machine with the related search. The study specifies factors influencing the garlic peeling process and recommends a design options for garlic peeling machine. These are based on a systematic study of the garlic peeling process. For which we consider literatures reviews & some of them are explained. In the present investigation, in the recent past human powered flywheel motor concept has been used for chaff cutter, bricks making, wood turning, cloth washing and turmeric polishing. The machine uses bicycle technology, with speed increasing gearing and a flywheel, which drive the process unit through a spiral jaw clutch and torque increasing gearing. Pedal power is used transmit this power to run the machine by the operator. Power can be transmitted through crank chain to free wheel to the working unit. This human powered flywheel motor concept (HPFM) provide new era in the human powered agriculture processing, harvesting, post harvested operations equipments. Considering social, cultural and environmental factor as well as in many rural operations utilizing unskilled worker and in Vidharbha region there is more problem of electricity so this kind of HPFM concept is helpful in driving various rural machines. The machine is economically viable, can be adopted for human powered process units which could have intermitted operation without affecting the end product.

**Keywords**—Garlic peeling machine , Human Power Flywheel Motor.

### INTRODUCTION

Garlic (*Alliulli salivulli* L) the spice of human life, is one of the important perennial bulb crops of the lily family (Liliaceae) grown all over the plains of India and used as a spice or a condiment throughout India. Garlic bulbs are valued for their flavor and command an extensive commercial importance because of their wide medicinal value nad application in food and pharmaceutical preparations. As a classic ingredient in pickles, chutneys, curries powders, curried vegetables, meat preparations etc. garlic has a powerful aroma and pungent taste. The use of garlic as condiment, garlic oil as insecticide, garlic paste as biofungicide, garlic residue as antibacterial agent and whole garlic as medicine including use for cancer treatment and in human nutrition are now recognized.India ranked second after China in world's garlic production with an annual production of 0.50 million tonnes.

Garlic processing involves bulb breaking, peeling, dehydration, grinding, packaging and storage. Garlic peeling is one of the most important and essential key unit operations prior to any subsequent processing activity. During garlic peeling the thin membranous skin is to be removed off from the segments. Very little work has been done on the garlic peeling and it is restricted to traditional peeling method only. Traditional peeling method viz.; hand peeling, flame

peeling, oven peeling, and chemical peeling are being used in processing industries, big restaurants, hotels and kitchen. These are laborious, time consuming, cost intensive and restrict speed of processing activity.

## EARLIER WORK IN GARLIC PEELING

A report submitted by Prof. Rajendra Prasad, IIT Delhi on the topic “A Technology Package of Garlic Processing for Value Addition” to Centre for Rural Development and technology, he emphasizes on the development of different garlic processing machines for the development of rural area.

All India Coordinated Research Project on Post Harvest Technology, a project coordinated by Dr. S.K. Nanda, an improved garlic bulb breaking machine (cost Rs 11000, capacity 800 kg/h), a garlic clove flaking machine (cost Rs 11,000, capacity 420 kg/h) as well as a garlic peeling machine (cost Rs 10,000 for batch type and Rs 70,000 for continuous type, both capacities 15-22 kg/h) have been developed by Udaipur centre to remove the drudgery and mechanize these operations. First two prototypes have been transferred to 3 manufacturers each



Fig.1 Garlic peeling machine developed at Udaipur centre

Nagarajan (45) lives at Usilampatti, a small village 40 km away from Madurai in Tamilnadu. Nagarajan's close interaction with the pickle manufacturers exposed him to the practices prevailing in the industry. Nagarajan successfully designed and developed a garlic-peeling machine in 2002 after two years of hard work. M. Nagarajan has modified a garlic-peeling machine significantly and this improved machine address the two-fold problem of the pickle industry, namely, inefficiency due to low degree of automation, and short supply of labour during peak seasons, which limits capacity. The garlic peeling machine has the capacity to peel 200 kg of garlic/hr. The garlic peeling machine consists of a 2 HP electric motor, blowers, a peeling chamber, inlet, outlet, exhaust pipe and drives. The peeling chamber has a

provision for garlic inlet and a shaft on which the blades are arranged in such a manner that there are six rows and each row consists of four blades placed at an equiangular distance of 90 degrees. These blades are made of the same material that is used for power transmission. The garlic cloves thus obtained are of a uniform size and can be neatly and conveniently collected and recovered. Another feature of this machine is that it is easy to construct, operate, and maintain. The blower removes excess moisture in the garlic and the separation of husk is innovative. This machine helps to achieve greater

productivity, is energy efficient and labour saving, and reduces the drudgery in the slow laborious process of peeling garlic. The manufacturing cost of a single prototype is Rs.52, 000/- This machine can also be used in other food processing industries apart from the pickle industry.



Fig.2 Garlic peeling machine developed by Nagrajan

Farm machinery and power technology who works on the pre and post harvesting machineries developed a garlic clove peeling machines (batch and continuous type) with 10-kg/hr capacity have been developed. The batch type garlic clove peeling has been evaluated and found satisfactory with 92-94 per cent efficiency. A flaking machine for pressing the cloves before dehydration has been designed. The machine is useful in flaking the cloves before drying, thereby enhancing the drying rate.



Fig. 3 Garlic peeling machine developed by Farm Machinery and Power Engineering

### III IDENTIFICATION OF THE PROBLEM

From the study of earlier work it is being observed that the machines which are developed are all of different capacities and power driven. Considering social, cultural and environmental factor as well as in many rural operations utilizing unskilled worker and in Vidharbha region there is more problem of electricity so this kind of HPFM concept is helpful in driving various rural machines. The machine is economically viable, can be adopted for human powered process units which could have intermitted operation without affecting the end product.

### IV CONCEPTUAL DESIGN

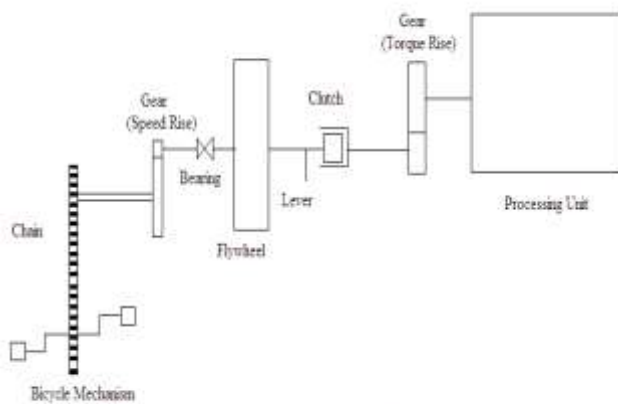

Fig. Human Powered Flywheel Motor Concept.

Fig. 4. Conceptual Model for Garlic Peeling Machine Energized by HPFM

From the literature search made produces data for

proposed model of garlic peeling machine consist of three sub system 1. Energy unit. 2. Transmission 3. Process Unit. Fig Line diagram of garlic peeling machine energized with HFM. This model consist of bicycle mechanism for energy unit which will consist big sprocket, and small sprocket, speed increasing gear pair, Flywheel which store this input energy. After storing the maximum possible energy in the flywheel, this available energy transmit towards processing unit with the help of spiral jaw clutch, before transmitting the flywheel will decelerate depending actual resisting torque offered by the process unit, this torque amplification before engagement of clutch done by gear pair.

## V LITERATURE SURVEY

[1] J. De La Cruz Medina and H.S. García, Instituto Tecnológico de Veracruz, Agricultural and Food Engineering Technologies Service, this paper said about the importance of garlic in the field of food and medicine field. It also gives the data about different garlic producing countries and various post harvesting processes applied for the storage for long time.

[2] Prof. Rajendra Prasad, IIT Delhi, A Technology Package of Garlic Processing for Value Addition  
Here Prof. Rajendra Prasad tells India is one of the leading Garlic (*Allium sativum*) producing countries. The area under cultivation and production of garlic in India (2010-11) is 200.70 thousand ha and 1061.85 thousand tons. Madhya Pradesh, Gujarat, Orissa, Rajasthan, Karnataka, Tamil Nadu, Maharashtra, Bihar and UP are the major Garlic producing states. Study revealed that the area and production of garlic is increasing in most of the states. The prominent Garlic production areas of Rajasthan state are in the districts of Chittoregarh, Jhalawar, Baran and Kota. Rajasthan has a specific Mandi for marketing of Garlic at Chhipabarod in Baran district.

The objective of the report was to find out the technology, equipment and machinery for processing of Garlic for value addition for setting up of rural enterprises.

[3] Dr S.K.Nanda, Project Co-ordinator AICRP on Post Harvest Technology, An improved garlic bulb breaking machine (cost Rs 11000, capacity 800 kg/h), a garlic clove flaking machine (cost Rs 11,000, capacity 420 kg/h) as well as a garlic peeling machine (cost Rs 10,000 for batch type and Rs 70,000 for continuous type, both capacities 15-22 kg/h) have been developed by Udaipur centre to remove the drudgery and mechanize these operations. First two prototypes have been transferred to 3 manufacturers each.

[4] Nagarajan (45) lives at Usilampatti, a small village 40 km away from Madurai in TamilNadu. Nagarajan's close interaction with the pickle manufacturers exposed him to the practices prevailing in the industry. Nagarajan successfully designed and developed a garlic-peeling machine in 2002 after two years of hard work. M. Nagarajan has modified a garlic-peeling machine significantly and this improved machine address the two-fold problem of the pickle industry, namely, inefficiency due to low degree of automation, and short supply of labour during peak seasons, which limits capacity. The garlic peeling machine has the capacity to peel 200 kg of garlic/hr. The garlic peeling machine consists of a 2 HP electric motor, blowers, a peeling chamber, inlet, outlet, exhaust pipe and drives. The peeling chamber has a provision for garlic inlet and a shaft on which the blades are arranged in such a manner that there are six rows and each row consists of four blades placed at an equiangular distance of 90 degrees. These blades are made of the same material that is used for power transmission. The garlic cloves thus obtained are of a uniform size and can be neatly and conveniently collected and recovered. Another feature of this machine is that it is easy to construct, operate, and maintain. The blower removes excess moisture in the garlic and the separation of husk is innovative. This machine helps to achieve greater

productivity, is energy efficient and labour saving, and reduces the drudgery in the slow laborious process of peeling garlic. The manufacturing cost of a single prototype is Rs.52, 000/- This machine can also be used in other food processing industries apart from the pickle industry.

[5] Dhananjay G. Dange, Dr. S. K. Choudhary, A. P. Ninawe, This paper presents the methodology for design and fabrication of garlic peeling machine with the related search. The study specifies factors influencing the garlic peeling

process and recommends a number of design options for garlic peeling machine. These are based on a systematic study of the garlic peeling process and testing of a prototype model of garlic peeling machine. For which we consider literatures reviews & some of them are explained.

[6] S.M.Moghe, K.S.Zakiuddin “Design and Development of Turmeric Polishing Machine Energized by Human Power Flywheel Motor.”-A past review, this paper gives the use of HPFM method successfully applied to turmeric polishing method.

## VI ACKNOWLEDGMENT

My sincere thanks to Prof. Dr.K. S. Zakiuddin Head of Department of Mechanical Engineering Department for this kind co-operation, continuous encouragement and reviewing my work frequently I would also thankful and very much to Prof. Dr. M.K. Sonpimpale coordinator Mechanical Department.

## VII CONCLUSION

The main conclusion will be drawn find out whether it is possible to make the power operated garlic peeling machine to work on Human Powered Flywheel Motor Concept with the same output.

## REFERENCES:

- [1] J. De La Cruz Medina and H.S. García, Instituto Tecnológico de Veracruz, Agricultural and Food Engineering Technologies Service.
- [2] Prof. Rajendra Prasad, IIT Delhi, Final Report of Sub-Project , A Technology Package of Garlic Processing for Value Addition, July 01, 2012 – December 31, 2012
- [3] Dr S.K.Nanda Project Co-ordinator AICRP on Post Harvest Technology, All India Coordinated Research Project on Post Harvest Technology.
- [4] M. Nagarajan, Garlic Peeling Machine, National Innovation Foundation India, 2005.
- [5] Dhananjay G. Dange, Dr. S. K. Choudhary, A. P. Ninawe, Methodology for Design and Fabrication of Garlic Peeling Machine-A Review
- [6] S.M.Moghe, K.S.Zakiuddin “Design and Development of Turmeric Polishing Machine Energized by Human Power Flywheel Motor.”-A past review.
- [7] Field Worthy Post Harvest Technologies and Machines: At a Glance, a Technical Bulletin 2001/1 compiled and edited by Dr. N. K. Jain, Dr. V. D. Mudgal and Dr. K. C. Sharma published under All India Coordinated Research Project on Post Harvest Technology, Directorate of Research, Department of Processing and Food Engineering, College of Technology and Engineering, Maharana Pratap University of Agriculture and Technology, Udaipur