

# Design & Analysis of Tack Welding Fixtures for the Parts of Compactor

Vinay T D <sup>[1]</sup>, Shivakumar <sup>[2]</sup>, Karthik Y C <sup>[3]</sup>, Madhu S <sup>[4]</sup>

[1],[2],[3],[4] Students of B.E in Mechanical Engineering, Department of Mechanical Engineering, Reva institute of Technology, Bangalore-560065, Karnataka, India.

E-mail -vinay.td94@gmail.com

**Abstract** - For the growing heavy industrial sectors the demand for compactors is increasing day by day. Therefore, the company must meet the demand through the available facilities so that the company has to sophisticate the manufacturing processes in the existing plant. Despite existing models in other company's being manufactured in the plant there is a need and demand for different higher capacity models. In this paper, an attempt has been made to Develop, Modify and Generate concepts to mount the sub-assemblies from the compactor components onto a Fixture to perform Tack Welding on the sub-assemblies. Techniques suggested in this paper help in saving Cycle time per Job and also help in reducing the Man hours, which might otherwise have been spent on manual Welding of all the Sub-Assemblies, by making the process Automatic. Analysis has been done to calculate the stress, strain & deformation and also theoretical calculations has been done. Comparison is done between the ansys results & theoretical results. The fixture design is carried out by using CATIA V5 R20 Modeling software and the components are analyzed by finite element method (FEM) using Ansys software.

**Keywords** - Compactor, fixture, Tack Welding, FEM.

## I. INTRODUCTION

A compactor (also called as road roller) is an engineering vehicle used to compact soil, gravel, concrete or asphalt in the construction of roads and foundations, similar rollers are used also at landfills or in agriculture. Normally powered by hydraulics, compactors take many shapes and sizes. In construction, there are three main types of compactor: the plate, the jumping jack and the road roller. The roller type compactors are used for compacting crushed rock as the base layer underneath concrete or stone foundations or slabs. Road rollers may also have vibrating rollers.



Fig1 Asphalt Compactor-990

A few notable manufacturers of compactors are:

- L & T Construction Equipment
- Caterpillar Inc.
- JCB
- Volvo Construction Equipment

A fixture is a device for locating, holding and supporting a work piece during a manufacturing operation. Fixtures are essential elements of production processes as they are required in most of the automated manufacturing, inspection, and assembly operations. Fixtures must correctly locate a work piece in a given orientation with respect to a cutting tool or measuring device, or with respect to another component, as for instance in assembly or welding. Such location must be invariant in the sense that the devices must clamp and secure the work piece in that location for the particular processing operation. Fixtures are normally designed for a definite operation to process a specific work piece and are designed and manufactured individually. [1].

Generally, all fixtures consist of the following elements [2]:

- **Locators:** A locator is usually a fixed component of a fixture. It is used to establish and maintain the position of a part in the fixture by constraining the movement of the part.
- **Clamps:** A clamp is a force actuating mechanism of a fixture. The forces exerted by the clamps hold a part securely in the fixture against all other external forces.
- **Fixture Body:** Fixture body, or tool body, is the major structural element of a Fixture. It maintains the relationship between the fixturing elements namely, Locator, clamps, supports, and the machine tool on which the part is to be processed.
- **Supports:** A support is a fixed or adjustable element of a fixture. When severe part displacement is expected under the action of imposed clamping and processing.

“**Tack Welding**” refers to a temporary weld used to create the initial joint between two pieces of metal being welded together.

**Tack Welding** is an integral part of the welding process and very important to the ultimate success of any welding projects.

Even though these two **Tack Welds** are just the initial part of the process, the welds should be fundamentally sound, considering they provide the foundation for the entire joint.

Benefits of **Tack Welding** include:

- Ease of removal in order to correct improper alignment with components you're welding together.
- Stabilizes the overall alignment of components you're welding together.
- Reduces movement and distortion during the welding process.
- Offers temporary joint strength if an object needs to be moved or repositioned during the welding process.

## II. PROBLEM DEFINITION

Presently there are no fixtures for the compactor parts, this is otherwise being welded by using hoist hook carriers and rotated to desired positions every time by cranes also measuring dimensions every time so which leads to high 3m's (money, men, machine) and increases manufacturing lead time and extremely unsafe. So, it is necessary to develop a fixture to reduce the cycle time of a compactor.

## III. OBJECTIVES

The main objective of this paper is to design a Tack Welding Fixtures, locating fixtures & templates for manufacturing of sub-assemblies & main assembly of front chassis of compactor.

Benefits of fixture are as follows:

- **Productivity:** Jigs and fixtures eliminate individual marking positioning and frequent checking. This reduces operation time and increases productivity.
- **Skill reduction:** Jigs and fixtures simplify locating and clamping of the work pieces. Tool guiding elements ensure quick and correct positing of the tool with respect to the work piece. There is no need of skillful setting of the work piece or tool. Any average person can be trained to use jigs and fixtures. The replacement of a skilled labor with unskilled labor can effect substantial saving in labor cost.
- **Interchangeability:** Jigs and fixtures facilitate uniform quality in manufacturing. There is no need for selective assembly. Any parts of the machine would fit properly in assembly and similar components are interchangeable.
- **Cost reduction:** Higher production, reduction in scrap, easy assembly and saving in labor cost result in substantial reduction in the cost of work piece produced with jigs and fixtures.

## IV. METHODOLOGY

The following flow chart shows the methodology in designing the fixtures:-

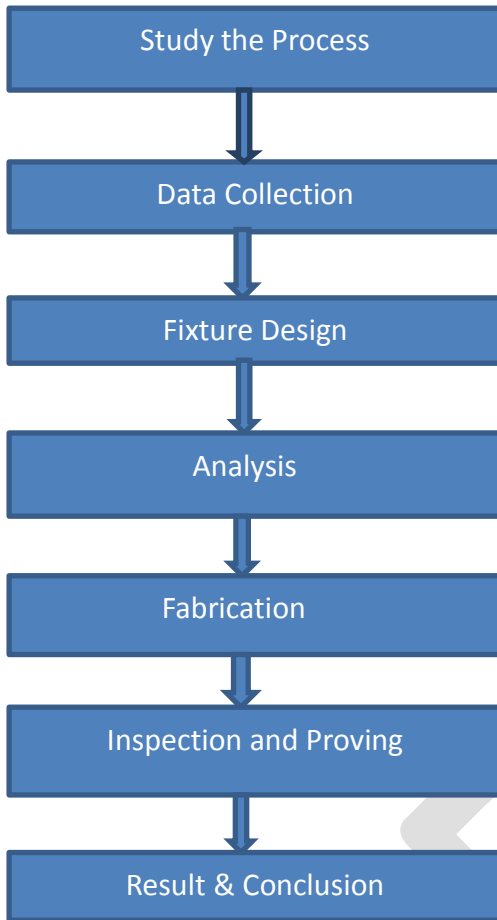

Fig 2 Methodology flow chart

## V. FIXTURE DESIGN

### 5.1 Fixture Design

Fixture planning is to conceptualize a basic fixture configuration through analysing all the available information regarding the material and geometry of the work piece, operations required, processing equipment for the operations and the operator. Fixture element design is either to detail the design drawings committed on paper or to create the solid models in a CAD system of the practical embodiment of the conceptual locators, clamps and supports. It is possible to use standard designs or proprietary components. The following outputs are included in the fixture plan:

- Fixture type and complexity.
- Number of work pieces per fixture.
- Orientation of work piece within fixture.
- Locating datum faces.
- Clamping surfaces.
- Support surfaces.

### 5.2 3-2-1 Principle of location-

The 3-2-1 principle is also known as six point principle which is used to constrain or prevent the body from moving in any direction along x-x, y-y and z-z axis.

### 5.3 Fixture design criteria

The following design criteria must be observed during the procedure of fixture design:

- Design specifications.
- Factory standards.
- Ease of use and safety.
- Minimum changeover / set up

- Economy

#### 5.4 Materials used in this fixture are as follows

- Mild steel - St - 42.
- Carbon steel - En353/354.

**Mild steel (St-42)** is a low carbon steel with no precise control over the composition or mechanical properties. The cost is low in comparison with other steels and this is used for covers, sheet metal work, tanks, fabricated items, etc.

Fixture components made out of mild steel are Main plate, Locator holder, Locating pin holder, Mounting block, Base plate, Spacer plate, Side plate, Locator plate and Base plate.

**Carbon steels** are medium carbon steels with a carbon percentage varying between 0.35% and 0.6%. Carbon steel is the preferred steel of this category and is suitable for applications such as shafts, gears, keys footed clutch, threaded fasteners requiring high strength, pins, etc. Carbon steel can be induction hardened for wear resistance.

#### VI.COMPONENT DETAILS

The three main components of compactor are as follows:-

- 1) Steering mount beam
- 2) Side bracket
- 3) Vibrating shaft

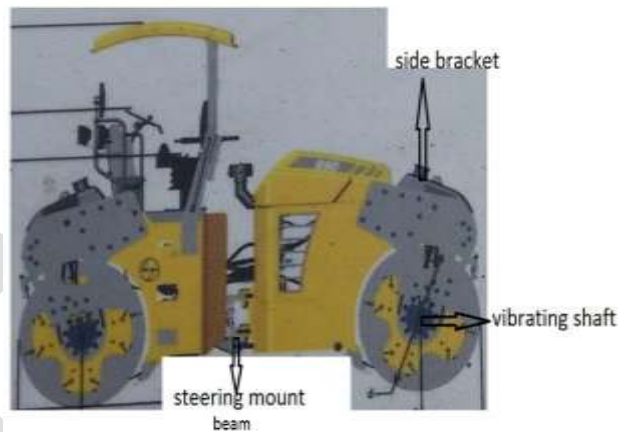

Fig.3 - 3-main parts shown in Asphalt Compactor-990

In this paper an attempt has been made to design & develop a tack welding fixtures for the parts of compactor shown in the above fig. Fixture design is generated by using CATIA V5 R20 modeling software.

#### 1. Steering Mount Beam-

Steering mount beam is the member which is used to operate the steering mechanism in order to control the directional movement of the compactor.

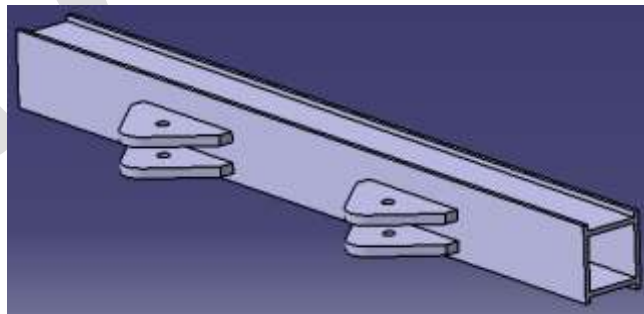

Fig.4 3D View of Steering Mount Beam

It consists of four lugs which have to be tack welded over the bracket plate. Hence, fixture has been designed to tack weld.

## 2. Side bracket-

Side Bracket is the structural member which is used to connect the front chassis or rear chassis with the roller drum with the help of suspended frame.

Generally there are four side brackets are used in compactor. Two side brackets are used for the front chassis and remaining two side brackets are used for rear chassis.

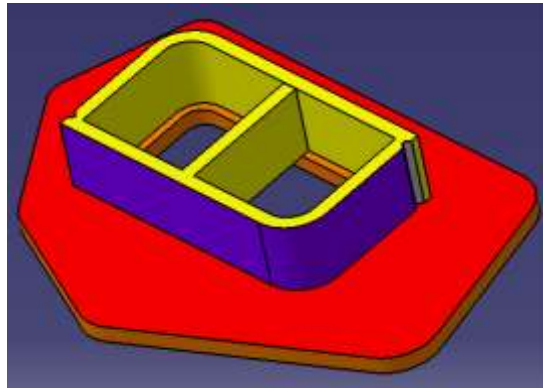

Fig.5 3D View of Side Bracket

Side bracket consists of the three main components which include:-

- 1) Main plate
- 2) Bent plates
- 3) Stiffener

These 3 parts have to tack welded over the bracket plate. Hence, the fixture has been developed.

## 3. Vibrating Shaft-

It is the heart of compactor. The main purpose of using the vibrating shaft is to create the vibrations inside the roller drum.

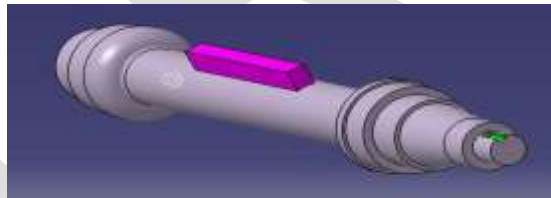

Fig 6 3D View of the vibrating shaft

Vibrating shaft consists of stopper. This stopper has to be properly placed over the shaft to create vibrations inside the roller drum. Hence, a fixture has been developed.

## VII.FIXTURE MODEL

### A.FIXTURE ASSEMBLY FOR STEERING MOUNT

### BEAM-

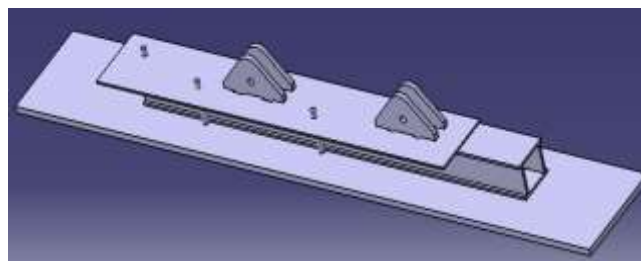

Fig 7 Fixture assembly for Steering Mount Beam

The steering mount beam consists of a one main bracket that is shown in above fig, and it has four lugs, that should be welded on top of main bracket. There are three locators placed as shown in above fig. A plate is placed over a main bracket in which four slots are produced in the plate with the help of laser cutting technique, with the help of locating pins the plate is placed over the main bracket, the plate guides the lugs to required location where it has to be welded. A small slot is provided to tack weld the lugs in plate. After tack weld the top plate is removed manually. Same procedure is carried out to perform the number of operations.

### B.FIXTURE ASSEMBLY FOR SIDE BRACKET-

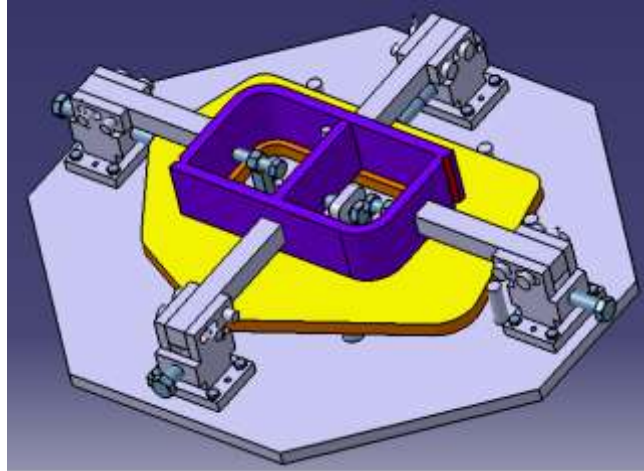

Fig 8 3D View of Fixture assembly for side bracket

Side bracket is a structural member which consists of two bending plates, one bracket (Irregular plate), and one stiffener, so the side bracket is made up of three members as mentioned above which are fabricated together to get a single structure. In order to fabricate these members welding technique is used.

The side bracket is of two different kinds which are one is left hand, right hand side brackets. Instead of designing the fixtures for the LH and RH separately, we are designing common fixture for the both LH and RH bracket.

Fixture assembly of side bracket mainly consists of base plate (on which remaining components are mounted), four swing locators, four rest pads, four locating pins & three screw clamps.

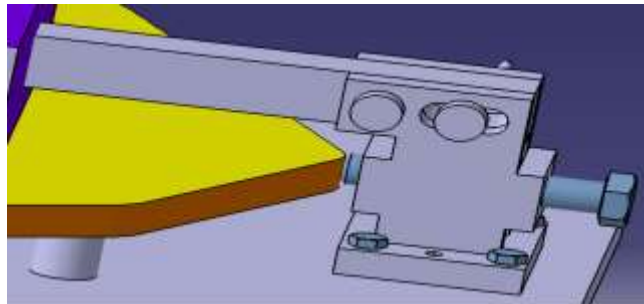

Fig 9 Swing Locator

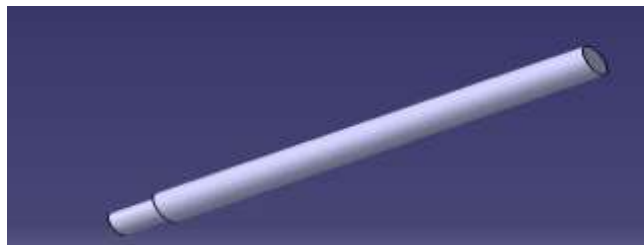
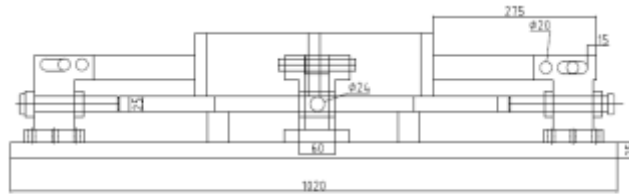

Fig 10 Stiffener locating pin

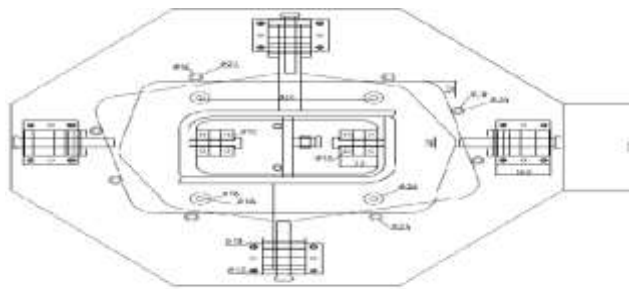

Fig 11 Rest Pad



FRONT VIEW

Fig 12 2D front view of fixture assembly



TOP VIEW

Fig 13- 2D Top View of fixture assembly

### C. FIXTURE ASSEMBLY FOR VIBRATING SHAFT-

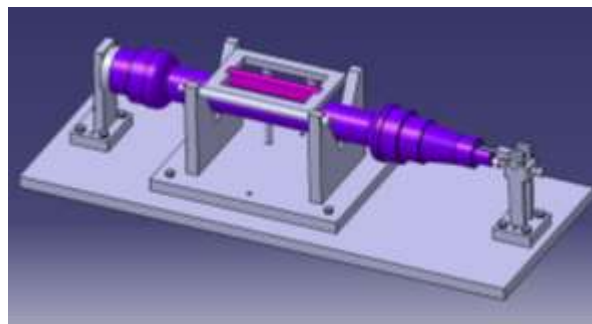

Fig 14- 3D View of fixture assembly for vibrating shaft

It is the heart of Compactor, In order to get the proper amplitude of vibrations; the stopper has to be placed in correct position. If the stopper is not positioned, it will not create the required frequency of vibrations. It consists of V-Block, Swing plate, tube, stopper, clamping bracket and rest pads as shown in the fig.

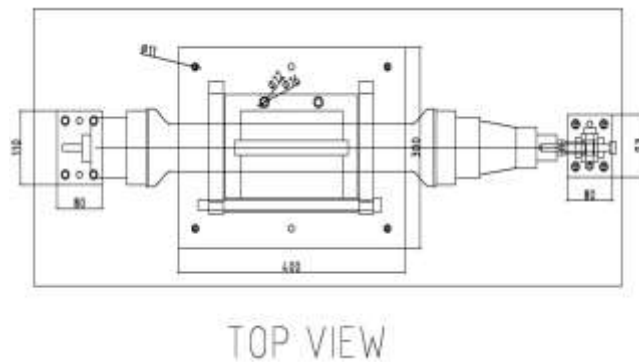

Fig 15- 2D Top view of fixture assembly for vibrating shaft

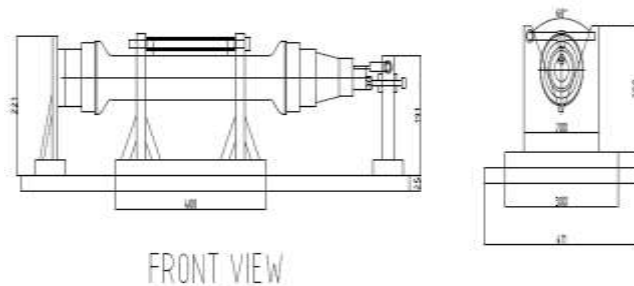

Fig 16- Front View of Fixture assembly for vibrating shaft

## VIII. ANALYSIS

Analysis has been carried out by using finite analysis method with help of ansys software. The analysis has been carried out in two stages. In the first stage the solid model of the component is selected and geometric conditions are selected, direction of the force is selected and results are evaluated using the software. In the second stage the boundary conditions are selected and then results are evaluated using the software.

### 8.1 Analysis procedures

A typical analysis has three distinct steps:

- Build the model.
- Apply loads and obtain the solution.
- Review the results.

The procedure for a static analysis consists of these tasks:-

- **Build the model:** The software permits the construction of the model from basic shapes. Alternatively a model from any compatible CAD software such as CATIA may be imported into ansys workbench and analyzed. For the better understanding and visualization of the design 3D modeling has been done.
- **Set solution controls:** The different inputs regarding the preprocessor stage have to be input into the software. Some of the inputs are units, types of analysis, element type, meshing of the component etc.
- **Set additional solution options:** This includes adding the material properties and selecting the results desired from the analysis. Material property includes Material type, Poisson's ratio, Mass density, Yield strength and Elastic modulus.
- **Apply the loads:** The different types and the magnitude of loads are applied. Constraining the points over the component, where the component is clamped and then the load is applied considering all the necessary forces.
- **Solve the analysis:** Gives appropriate results as selected.
- **Review the results:** The results are reviewed and the analysis is repeated by changing the variables if necessary.



## 8.2 Analysis on rest pads:

### Component description:

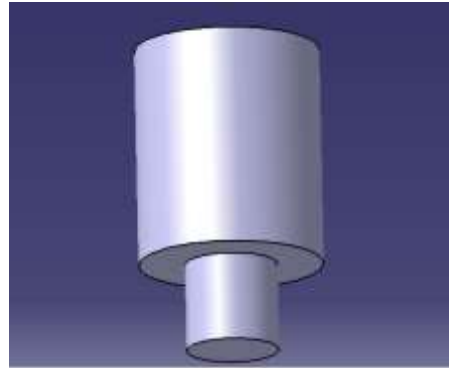

Figure.1 Rest Pad

The above fig shows the rest pad which is located inside the base plate. The main purpose of these pad pins is to rest or mount the side bracket assembly on it. It is also known as the pad pins.

Material – Structural Steel

Young's Modulus-  $2.1 \times 10^5$  N/mm<sup>2</sup>

Force applied-144.20N

Height of the component -50mm

Diameter of the component- 36mm

### Results-

The analysis can be done by applying an axial load of 144.20N.

Stress induced in the rest pad-

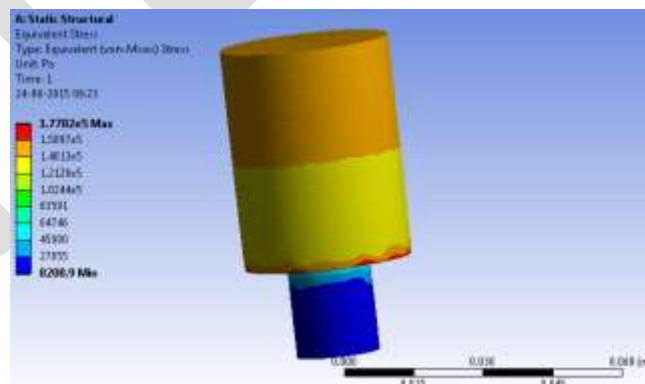

Fig 2 Stress Distribution in the rest pad

Strain induced in the rest pad-

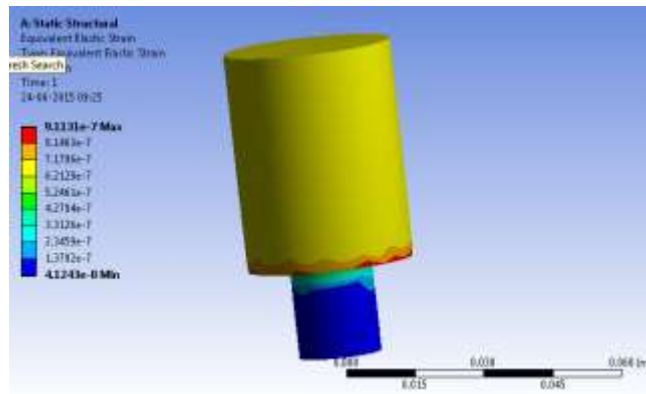

Fig 3 Strain Distribution in the rest pad

Deformation in the rest pad-

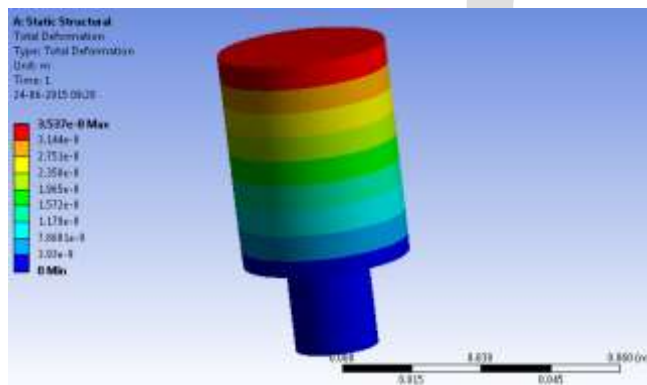

Fig 4 Deformation in the rest pad

## 8.5 Analysis on locating pins:

Component description:

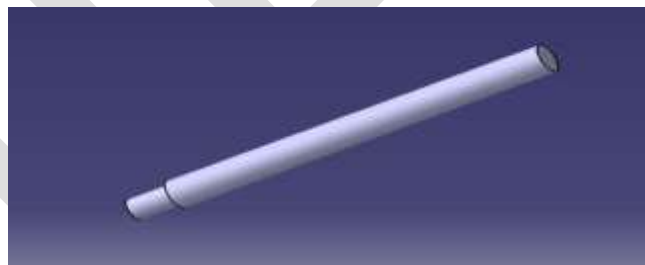

Figure 5 Locating Pin

The above figure 5 shows the pin which is located inside the base plate. The main purpose of this pin is to restrict the movement of the side bracket assembly and also to maintain a proper alignment of bracket over the pads.

Height of the component -75mm

Diameter of the component- 24mm

### Results

The analysis can be done by applying a bending load of 374.94N.

Stress-

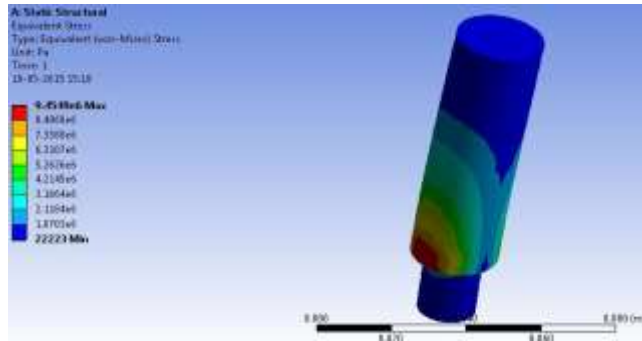

Fig 6 Stress Distribution in the locating pin

Strain

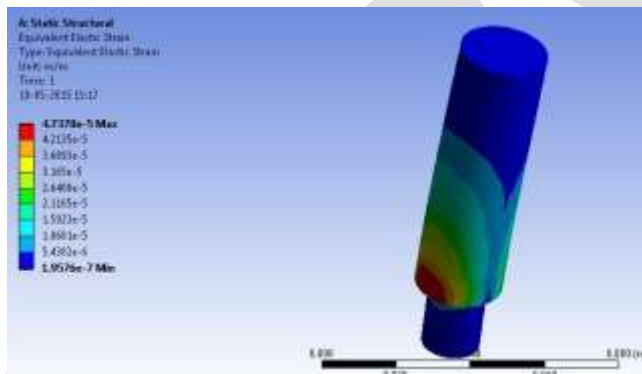

Fig 7 Strain Distribution

Deformation-

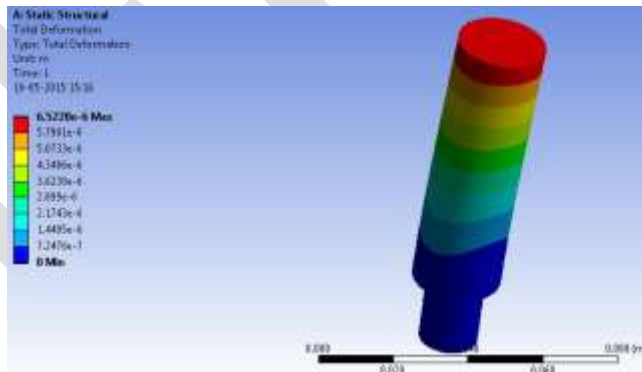

Fig 8 Deformation in the locating pin

## IX. THEORETICAL CALCULATIONS

### A. Theoretical Calculations on Rest Pad-

#### 1) Stress in the rest pad

By hook's law

$$\sigma = \frac{\text{force}}{\text{area}}$$

Force = 144.20N

Area  $A = \frac{\pi (D^2)}{4}$

$$A = \frac{\pi (36^2)}{4}$$

$$A = 1017.87 \text{ mm}^2$$

∴ Stress will be  $\sigma = \frac{\text{force}}{\text{area}}$

$$\sigma = \frac{144.20}{1017.87}$$

$$\sigma = 0.1466 \text{ N/mm}^2$$

**2) Strain in the rest pad**

$$\epsilon = \frac{\sigma}{E}$$

$$\epsilon = \frac{0.1466}{2.1 \times 10^5} \quad \epsilon = 6.980 \times 10^{-7}$$

**3) Deformation in the rest pad**

$$\Delta D = \frac{PL}{AE}$$

$$\Delta D = \frac{144.20 \times 50}{1017.87 \times 2.1 \times 10^5}$$

$$\Delta D = 3.5416 \times 10^{-5} \text{ mm}$$

**4) Factor of safety**

$$\text{FOS} = \frac{\text{Yield stress}}{\text{Allowable stress}}$$

$$4 = \frac{250}{\text{Allowable stress}}$$

Allowable stress = 62.5MPA

Serial no	Properties	Actual ( Ansys )	Theoretical
1	Stress N/mm <sup>2</sup>	0.1778	0.1466
2	Strain mm/mm	3.015* 10 <sup>-7</sup>	7.08 * 10 <sup>-7</sup>
3	Deformation mm	3.537 * 10 <sup>-8</sup>	3.341 * 10 <sup>-8</sup>

Table.1. Comparison between actual and theoretical values

**B. Theoretical Calculations on locating pin-**

From bending equation

$$\frac{Mb}{I} = \frac{\sigma}{c}$$

D= Diameter of pin=24mm

Length of pin=L=75mm

where **I= moment of inertia** =  $\frac{\pi (D^4)}{64} = 16286.01mm^4$

F=force+frictional force=374.93N.

Mb=force\*length  
=374.937\*75  
Mb = 28120.27N-mm

**1) Bending stress**

$\sigma_b = \frac{Mb}{I} * c$   
= (28120.27)/(16286.01)\*12

$\sigma_b = 20.71 N/mm^2$

**2) Maximum deflection**

Deflection=  $pl^3/3EI$

$\frac{374.937*75^3}{3*2*10^5*16286.01}$

Deflection =0.0168mm

Serial no	Properties	Actual ( Ansys )	Theoretical
1	Bending Stress N/mm <sup>2</sup>	9.46	20.71
2	Deformation mm	6.522 * 10 <sup>-3</sup>	16.18 * 10 <sup>-3</sup>

Table.2. Comparison between actual and theoretical values

**X. CONCLUSION**

- This project work deals with “Design and analysis of tack welding fixtures for the parts of compactor”. The project has been successfully carried out and also the AUTO CAD drawings of the Front view, Top View and Side View are shown.
- 3D model is generated using Catia V5 modelling software.
- Modifications are done on model to improve the design and quality.
- Analysis is done on modified model to find stress, deflection and strain.
- Comparison is done between ansys results and theoretical results.
- As per analysis results, this project work concludes that fixture models are safe design.

**XI. FUTURE SCOPE**

The use of fixtures has twofold benefits. It eliminates individual marking, positioning and frequent checking before machining operation starts, thereby resulting in considerable saving in set-up time. In addition, the usage of work holding devices saves

operator labor through simplifying locating and clamping tasks and makes possible the replacement of skilled workforce with semi-skilled labor, hence effecting substantial saving in labor cost which also translates into enhanced production rate.

## XII.ACKNOWLEDGMENT

We express our sincere gratitude to L&T Construction Equipment Limited, Bengaluru for this wonderful opportunity, where this project work is carried out. We thank Mr D P Samuel, Mr B. Kishore Kumar, Mr H V Vasuki, Mr Sudarshan M S and Mr Ravibhushan for their wonderful support. We take this opportunity to express our deep sense of gratitude to our guide, Mr Shivasharanayya Swamy, Assistant Professor, Department of Mechanical Engineering, Reva Institute of Technology & Management, Bengaluru, for the continuous support, encouragement and insightful suggestions which helped us successfully complete the project work.

## REFERENCES:

- [1] Luis E. Izquierdo<sup>1</sup>, S. Jack Hu<sup>1</sup>, Hao Du<sup>1</sup>, Ran Jin<sup>2</sup>, Haeseong Jee<sup>3</sup> and Jianjun Shi<sup>2</sup> “Robust Fixture Layout Design For A Product Family Assembled In A Multistages Reconfigurable Line” Department of Mechanical Engineering, The University of Michigan 2350 Hayward Street, Ann Arbor, MI 48109
- [2] Yu Michael Wang and Diana Pelinescu “OPTIMAL FIXTURE LAYOUT DESIGN IN A DISCRETE DOMAIN FOR 3D WORK PIECES” 2001 IEEE International Conference on Robotics & Automation Seoul, Korea • May 21-26, 2001
- [3] [http://www.wikipedia.org/wiki/Road\\_roller](http://www.wikipedia.org/wiki/Road_roller)
- [4] Siddesha K, Dr. D. Ramegowda “Design And Analysis Of Welding Fixture For the footrest stand component” in the International journal of engineering research & Technology ISSN: 2278-0181, Vol. 4 Issue 04, Pg-no-995-998, April-2015
- [5] P.H Joshi A text book of “JIGS AND FIXTURES” 2nd edition Tata McGraw-Hill Publishing Company limited, New Delhi.
- [6] Erik karl Henrickson, “JIGS AND FIXTURE DESIGN MANUAL” Industrial Press Inc., 01-Jan-1973