

# Design of a Keypad Operated CNC Drilling Router

Olufemi B. Akinnuli<sup>1</sup>, Vincent A. Balogun<sup>\*2</sup>, Tunde C. Akintayo<sup>1</sup>

<sup>1</sup>Department of Mechanical Engineering, Federal University of Technology, Akure, Nigeria.

<sup>2</sup>Department of Mechanical & Mechatronics Engineering, Afe Babalola University, Ado Ekiti, Nigeria

\*Corresponding author: E-mail: balogunav@abuad.edu.ng

**Abstract**— The CNC router can be adapted for drilling and engraving operations based on the imagination and creative skills of the operator. A CNC router consists of three main parts: a mechanical setup that can move in X, Y and Z directions, a driving circuitry which includes the stepper motor and a software program that controls the operation of the system. Although, CNC router is commonly and commercially available, the emphasis is to increase the understanding and encourage developing countries like Nigeria on the developmental process of the CNC router machine. This work presents the development of a CNC drilling router machine using a keypad with the aid of Autodesk 3D Max and Proteus 8 software. The CNC router has a liquid crystal display (LCD) which is linked to the microcontroller. The program of instructions is written in C program compiler. The column strength of the X, Y, and Z axis of the machine were evaluated to be 508.86N, 1142.5N and 7872.64N respectively while the critical speeds of the various axes were determined to be 3222, 7234.14 and 49847.78 RPM respectively. The forces due to the guide rails were evaluated to be 890 N on both the Y and Z axes. This gave a force moment along these axes to be 400.5 and 10.1 kNmm respectively. The stepper motor utilized for the machine has a 1440 steps/ rev, 500 RPM with 1/8 micro-stepping with a phase current of 3.5A and voltage of 2.45V. It is anticipated that the developed machine is able to drill plastics and soft wood materials. The development strategy will aid the CNC router design concept within the developing economy as Nigeria.

**Keywords**— CNC router, mechatronics system, machine design, CNC machine, microcontroller, drilling, router development.

## INTRODUCTION

Conventional Computer numerically controlled (CNC) machining is a technology which has set the manufacturing industry in an entirely new direction [1]. This has also changed the 'Business as Usual (BAU)' practice adopted through the use of conventional machine tools [2]. A CNC router is a computer controlled shaping machine. The tool paths can be controlled via computer numerical control system. Routing is usually used for high speed cutting, trimming, or shaping, on wood, light metals, plastics and many other materials. Also, a CNC router can perform machining operations (i.e. drilling, milling and cutting, engraving) and thermoforming of plastics by automating the trimming process. Schneider, [3] in 2010 reported that approximately 75% of all metal-cutting process is of the drilling operation. This therefore implies that drilling machines are one of the most commonly used industrial equipment. CNC drilling machine can be classified as CNC Printed Circuit Board (PCB) drill, CNC vertical drill, CNC deep-hole drill, drilling centre and other large CNC drilling machine. CNC machines are generally automated. Automation is the use of control systems and information technologies in order to reducing the need for human intervention. It is implemented with program of instructions combined with the control systems [4].

Machining is one of the most versatile and accurate of all manufacturing processes. This is as a result of its capability to produce a diversity of part geometries and geometric features [5]. Machining is a general term which refers to the selective removal of material from a part or work piece by a wedge shaped tool [6]. More recent advances in machining technology have made it possible to replicate extremely small tolerances on a large scale and exhibit superior finishing characteristics on the machined workpiece material [7]. The geometry of the part is achieved by the linear and rotary combinations of the workpiece and the cutting tool. For example, milling, shaping, planning, and sawing [4]. Due to the

relative cost and versatility, conventional CNC machining is still been adopted to manufacture large quantities of high-quality goods at unprecedented speed [8]. Modern day CNC machine now has new technologies with various milling features and functionalities [9] to ensure optimum performance.

### **COMPUTER NUMERICAL CONTROL AND COMPUTER NUMERICAL ROUTERS**

Numerical control or numerically controlled (NC) machine tools are machines that are automatically operated by commands that are received by their processing units. The Electronic Industry Association (EIA) defined CNC as 'a system in which actions are controlled by the direct insertion of numerical data at some point' [10]. The system must automatically interpret at least some portion of this data. The input signals (NC codes) through the controller are sent to the machine tool for the execution of the required task. However, for an open loop machine tool, the signals from the controller to the machine tool receive no information in return while a closed loop machine tool receives information back due to the feedback mechanism for cutting adjustments. These adjustments help minimize detrimental conditions such as tool deflection or work piece slip.

The 3-axis CNC router is a computer controlled shaping machine. The Numerical codes (g-codes) that relates to the Computer Aided Design CAD of the workpiece is generated and sent to the CNC router so that the part designed with the computer can be replicated. The 3-axis CNC router comprises of the base or table frame, cutting table, x, y and z-axis linear drive system, y-axis gantry, the cutting tool (spindle), CNC controller and computer system. The trend and applications of CNC router are well documented in literature [11]. Onwubolu et. al., [12] developed a PC-based computer numerical control (CNC) drilling machine. The authors adopted a PC as a separate front-end interface for the drilling machine. The system developed and integrated the customized machine control unit, enhanced parallel port communication and neural network based optimizer in order to find the best distance optimized sequence of points to be drilled. Salihmuhsin et al., [13] developed a PCB prototyping system such that it produced a trace line on a PCB board and drilled the holes on both end of the trace line.

### **STATEMENT OF PROBLEM**

In line with the sustainability agenda of United Nation Environment Program, UNEP, operations and processes are to produce more from less materials thereby increasing productivity at zero or near zero waste [14]. Furthermore, the growth of Nigeria manufacturing sector depends largely on its productivity and quality. Productivity level in Nigeria can be enhanced by having good machining processes which is actually the most versatile and accurate manufacturing processes and also having the capability to produce diversity of part geometries and geometric features using machines that can be controlled automatically with the computer. This could improve resource efficiency and sustainable manufacture. It is therefore envisaged that the CNC controlled toolpath be adopted to reduce human interaction in the drilling of holes since it is somewhat difficult to manually ascertain the locations of the holes to be drilled. Also, different size holes require the changing of the drill bit. This process is cumbersome and time consuming for repeated multiple jobs. This could lead to low productivity hence the need to automate the drilling process through the use of a CNC router.

### **AIM & OBJECTIVES OF THE STUDY**

The aim of this research is to design and produce an animated model of a CNC drilling machine router. The specific objectives of this study are to:

- Design a computer numerical control (CNC) drilling machine router operated using a keypad.
- Animation of the computer numerical control (CNC) drilling machine router.
- Development of a piece of software for controlling the direction of the stepper motors.
- Simulation of the machine.

### **RESEARCH METHOD**

#### **The Machine Frame**

The mechanical subsystems of the CNC router are those unit components which eventually make up the machine. For example, the mechanical subsystems comprises of the guide rail and bearings, the drive system, and the frame housing structure. Each of these systems has a direct impact on the qualities of a CNC. The materials selection for the mechanical subsystems has a direct impact on performance, precision, repeatability, longevity, and mechanical noise transfer into the parts.

The CNC machine frames (shown in Figure 1) are made of materials that have strength in order to support the weight of the gantry and the cutting head and at the same time withstand forces that could result from the cutting processes. Other design considerations for the machine frame include; the stiffness (to prevent any deflections due to both static forces and dynamic forces resulting from the acceleration of the tool head) and the total weight of the frame (contributes to both the static and the acceleration forces). Williams et al., [15] proposed the use of a range of different materials for the fabrication of the machine frame. This is as result of their exhibition of improved mechanical properties (i.e. modulus of elasticity, yield strength, and density). The ratio of the modulus of elasticity to density was calculated to give an indication of stiffness and the ratio of yield strength to density was found to give a strength value relative to weight [16]. The advantage of building the machine frame with aluminum is the high percentage of the weight-to-strength ratio it exhibits.

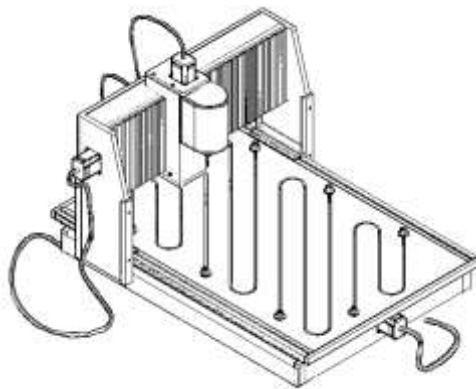

Figure 1: 2D Wireframe drawing of the proposed Router

## DRIVE SYSTEM

In achieving the transmission of the rotational motion of the stepper motor to the linear movement of the gantry and the motor of the drill machine, a 0.5" diameter, 10 threads per turn (TPI) and a 2- start ACME lead screw with an anti-backlash nut is utilized. The ACME lead screw is selected due to the several advantages it offers. It include no back-driving under load, readily available as standard part, low cost, fine leads, unusual diameters, adaptability of custom designed follower nuts to the lead screw and high loads capabilities. The selected stepper motor has 1440 steps per turn capacity (i.e.  $0.25^\circ$  per step to complete 1 revolution).

major diameter of screw,  $D = 0.5$  inches

number of threads per inches (TPI) = 10

number of turns per inches =  $\frac{TPI}{no\ of\ starts} = \frac{10}{2} = 5$  turns per inches

precision or steps per inches =  $1440 \times 5 = 7200$  steps per inches

Picth of the leadscrew can be estimated as shown in Equation 1.

$$pitch = \frac{1}{TPI} = \frac{1}{10} = 0.1 \quad (1)$$

Therefore,

$$Lead = pitch \times no\ of\ starts = 0.1 \times 2 = 0.2 \quad (2)$$

minor diameter,  $K_s = D - \frac{1.22687}{n}$

$$K_s = 0.5 - \frac{1.22687}{10}$$

$$K_s = 0.377 \text{ inches} \equiv 9.58 \text{ mm}$$

$$\text{minor diameter of the nut thread, } K_n = D - \frac{1.08253}{n}$$

$$K_n = 0.5 - \frac{1.08253}{10}$$

$$K_n = 0.392 \text{ inches} \equiv 9.96 \text{ mm}$$

$$\text{basic pitch diameter, } D' = D - \frac{0.64954}{n}$$

$$D' = 0.5 - \frac{0.64954}{10}$$

$$D' = 0.435 \text{ inches} \equiv 11.05 \text{ mm}$$

$$\text{Stress area, } A_s = 0.7854 \left\{ D + \frac{K_s}{2} \right\}^2$$

$$A_s = 0.7854 \left\{ 0.435 + \frac{0.377}{2} \right\}^2$$

$$A_s = 0.1295 \text{ inches} \equiv 3.29 \text{ mm}$$

### GUIDE RAIL AND BEARINGS

One of the machine's frame subsystems to be considered in the design is the conventional railing system which consists of a linear motion bearing and shaft assembly which would simply allow unrestricted movement along their lengths. For the Y and Z-axis, 2 pieces steel shafts of 16 mm diameter and 400 mm length were assembled with four rubber bushings to aid smooth transition of the motor along the steel shafts. A ball bearing design is incorporated on the X-axis. This is to reduce the rotational friction and to provide radial and axial loads support along the X-axis. It achieves this by using at least two races to contain the balls and transmit the loads through the balls. Because the balls are rolling, they have a much lower coefficient of friction than if two flat surfaces were sliding against each other.

#### *Determining the Column Strength, Critical Speed and Force analysis*

For each of the table axis, the column strength and critical speeds under the maximum weight were evaluated and shown in Table 1. Equations 3, 4 and 5 are adopted to evaluate the column strength, critical speed and Bending moment respectively along the X, Y and Z-axis.

The maximum load the lead screw can withstand in compression before failure is the Column strength, any compression load which exceeds this estimated column strength will cause the lead screw to buckle.

$$C_l = \frac{[N \times 14.03 \times 10^6 \times k_s^4]}{L^2} \quad (3)$$

$$C_s = \frac{[N \times 4.76 \times 10^6 \times K_s]}{L^2} \quad (4)$$

Where;

$C_l$  = Column strength,  $C_s$  = critical speed,  $N$  = fixity type (fully supported frame type being used in this design) = 1.00,  $L$  = length of the lead screw = 23.6 inches or 600 mm,  $k_s$  = minor diameter of the x – axis lead screw = 0.377 inches

Table 1: Column Strength, The Critical Speed and Force analysis

Axis	Column Strength (N)	Critical Speed (RPM)
X	508.86	3222
Y	1142.5	7234.14

Z	7872.64	49847.78
---	---------	----------

## FORCE ANALYSIS

When the machine is in operation, there are certain forces and moments worthy of consideration in the design of the machine in order not to stress the machine beyond what it can actually take for optimum performance.

### Y-Axis Gantry Assembly

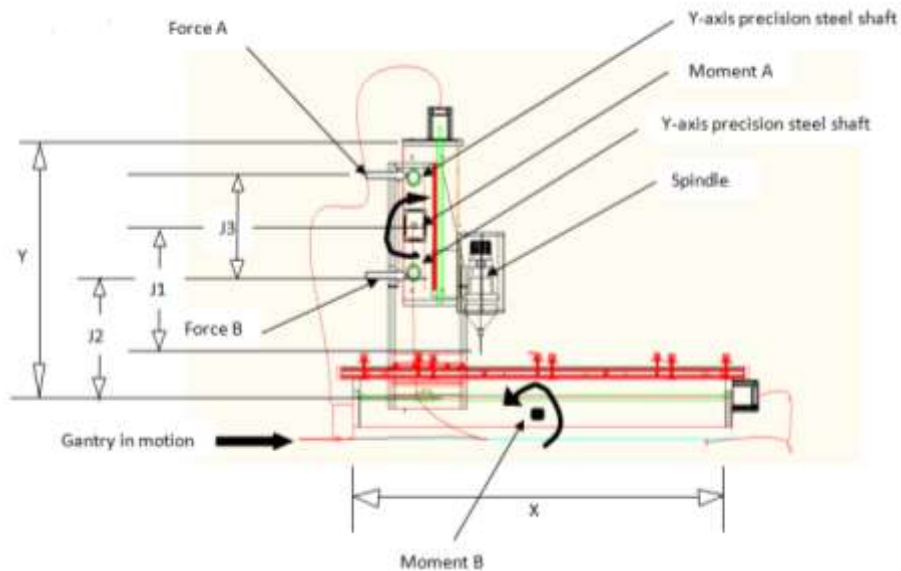

Figure 2: Analysis of the Y-axis assembly Parameters

From Figure 2,

$J1$  = distance between cutting tool and center between the two – axis precision steel shaft = 400mm

$J2$  = distance between lower Y – axis precision shaft and bottom X – axis linear precision shaft = 450mm

$J3$  = distance between lower and upper Y – axis precision steel shaft = 300mm

When the gantry moves by action of the CNC drive system and the spindle cuts, this cutting action opposes the movement of the gantry resulting in a cutting force ([www.cncroutersource.com](http://www.cncroutersource.com)).

The cutting force being applied at distance  $J1$  results in moment at point A as shown above.

$$\text{moment A} = J1 \times C_f$$

where:

$$J1 = 400\text{mm}$$

Maximum expected cutting force,  $C_f = 150\text{lbs}$  or  $667.5\text{N}$

$$\text{Moment A} = 667.5 \times 400 = 267\text{kNmm}$$

It is to be pointed out that the longer the distance  $J1$ , the larger will be the moment even if our cutting force remains the same.

The moment A, resulting here results in 2 forces on the Y-axis precision steel shaft. The forces resulting are labeled as force A & B, as shown above.

Force A = Force B (for a safe operation of the machine)

$$\text{Force A} = \frac{\text{moment A}}{2} \div \left(\frac{1}{2}J3\right)$$

$$\text{Force A} = \frac{\text{moment A}}{J3}$$

where:

$$J3 = 300\text{mm}$$

$$\text{Force } A = \frac{267000}{300} = 890\text{N}$$

It is noted that as the vertical distance, J3 between the two precision steel shafts increase, the resulting forces A and B reduces.

This aids in reducing the amount of centralized torque which is on the gantry itself.

In finding the second moment B;

$$\text{Moment } B = J2 \times \text{force } A$$

where:

$$J2 = 450\text{mm}$$

$$\text{Moment } B = 450 \times 890 = 400.5\text{kNm}$$

This moment B could cause the whole gantry to rock due to the cutting force, hence, we aim at reducing it to barest minimum by reducing J3 so to have equal amount of force on our linear bearings and reduced deformation and chatter of the machine

### **Forces and Moment on the Z-axis Assembly**

While the machine moves in the Z-axis direction to the right, riding on the Y-axis linear bearing rail, the plunge arm is at a maximum Z travel and cutting into a material as it moves from left to right. This cutting action taking place produces a cutting force which opposes the movement of the Z-axis assembly.

This cutting force created causes a moment C as illustrated below:

$$\text{Moment } C = J7 \times \text{cutting force}$$

Taking the thickness of the plunger arm as 15mm

$$\text{Moment } C = 15 \times 667.5 = 10.1\text{kNm}$$

This moment C causes a torque on the plunger arm in the opposing direction of the cutting force, which in turn, torques the entire Z-axis assembly. This moment results in resultant forces which are applied to the Z-axis linear bearing rails and even the Z-axis linear bearings themselves.

As J9 increases in length, the resultant forces decreases.

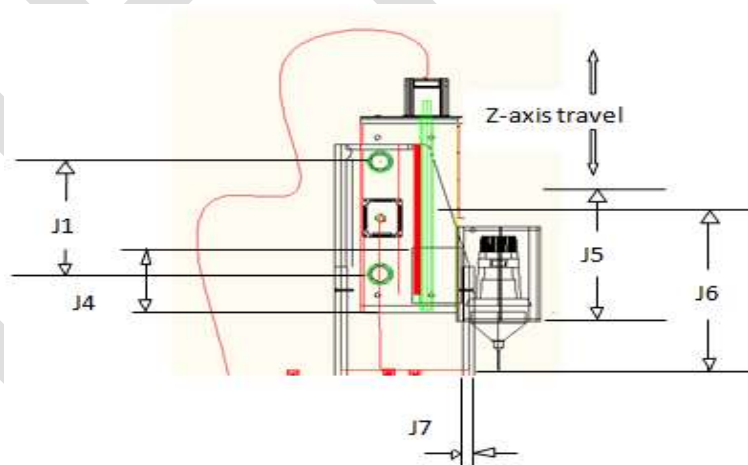

Figure 3: Side view of the Z-axis assembly

From Figures 3 and 4:

J1= distance between cutting tool and centre between the two Y-axis precision steel shaft

J4= vertical distance between the upper and lower sets of the Z-axis linear bearing

J5= the length of the spindle attachment plunger arm

J6= distance between the cutting force and  $\frac{1}{2}J4$

$J7$  = thickness of the plunge arm

$J8$  = the width of the Z – axis assembly

$J9$  = horizontal distance between the Z – axis line precision shaft

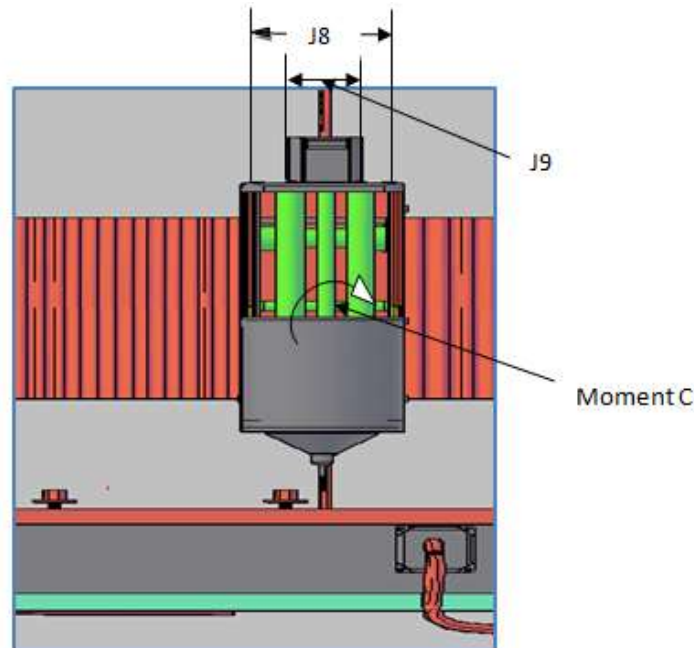

Figure 4: Front view of the machine

Cutting speed, depth of cut, feed rate are collectively known as cutting conditions of a machine. They form the three dimensions of the cutting process.

#### CALCULATION FOR LEAD SCREW ASSEMBLY VELOCITY (IN IPM)

We need to estimate for the desired velocity at which the lead screw assembly is to move. It is often measured in inches per minute (IPM).

$$RPM = \frac{\text{velocity (inch/min)}}{\text{lead (in/rev)}}$$

$$\text{velocity} = RPM \times \text{lead}$$

Where:

$$\text{Lead} = 0.2$$

$$\text{RPM of the stepper motor} = 500 \text{ rpm}$$

$$\text{velocity} = 0.2 \times 500 = 100 \text{ IPM}$$

In the X-axis;

With our lead screw being 23.6 inches in length, pitch of 0.1'' and lead of 0.2, 500 RPM motor would give a rapid feed or velocity of 100 inch/minute, or taking 14.16 seconds for the full slide travel.

In the Y- axis;

With our lead screw being 15.75 inches in length, pitch of 0.1'' and lead of 0.2, 500 RPM motor would give a rapid feed or velocity of 100 inch/minute, or taking 9.45 seconds for the full slide travel.

In the Z-axis;

With our lead screw being 15.75 inches in length, pitch of 0.1'' and lead of 0.2, 500 RPM motor would give a rapid feed or velocity of 100 inch/minute, or taking 9.45 seconds for the full slide travel.

### **Motor step/inch calculation**

This is regarded as the number of steps the motor runs in order for the nut to move 1 inch on the lead screw in either axis. The equation for this estimate has put into consideration also the type and size of our lead screw, as well as the micro stepping.

$$\text{steps/inches} = \text{leadscrew's} \frac{\text{rev}}{\text{inch}} \times \frac{1}{\text{microstep}} \times \text{motor's} \frac{\text{step}}{\text{rev}}$$

Where:

The leadscrew's (rev/inch) = 5 rpi

Motor's (step/ rev) = 1440 steps/rev

Motor's microstepping of 1/8

$$\frac{\text{steps}}{\text{inch}} = 5 \times \left( \frac{1}{8} \right) \times 1440 = 57,600 \text{ steps per inch}$$

#### **2.7.1 The motor step per second**

This estimate is essential so to specify the clock speed which our computer system must send pulses out so to ensure that the machine moves at a specific speed. If the clock speed is set too low while machine speed is high could have a negative effect on the machine's performance in terms of missed steps or limited speed.

$$\frac{\text{steps}}{\text{second}} \text{ Hz} = \frac{\text{inch}}{\text{minute}} \times \frac{\text{step}}{\text{inch}} \times \frac{1 \text{ minute}}{60 \text{ seconds}}$$

$$\frac{\text{steps}}{\text{second}} \text{ in Hz} = 100 \times 57,600 \times \frac{1}{60}$$

$$\text{clock's steps per second} = 96,000\text{Hz} = 96\text{kHz}$$

## **THE ELECTRONIC SYSTEM**

### **Stepper motor selection**

There are two electromechanical approaches that can be used to drive the mechanical system. There is a servo controlled and the stepper motor drive approach. The servo systems have a basic drive system with feedback, stepper motors have multiple methods in which they can be driven. These techniques can be simple or complicated, and it becomes a question of performance versus cost which determines the type used.

Stepper motors are well known to use between 50 to 100 pole brushless motors. They can accurately move between step positions because of the high number of poles. Stepper motors move incrementally using pulses of current and do not require the use of a closed loop feedback system. The high number of poles of the stepper motor helps it in delivering more torque at lower speeds than of the same size servo motor. Torque reduction of the stepper motor at higher speeds can however be minimized by increasing the driving voltage of the motor. In this project a motor with 1440 steps/ rev, 500 rpm, 1/8 micro-stepping is used to powering the lead screw.

### **The PIC 18F452 Microcontroller**

The CNC controller is well regarded as the brain of a CNC system. The controller completes the all-important link between a computer system and the mechanical components of the developed CNC router machine. The primary task of the CNC controller is to receive conditioned signals from the computer and interpret those signals into various mechanical motions as required through the stepper motor output. The microcontroller consists of a microprocessor, memory, I/O capabilities, and other on-chip resources. The choice of microcontroller is governed by low cost, versatility, ease of programming, and sizes. The PIC microcontroller 18F452 adopted for this work has Liquid Crystal Display LCD that displays the X, Y and Z and spindle speed instructions being sent to the machine. The microcontroller is interfaced with the LCD using the C programming software and the Proteus simulation software.



## RESULTS AND DISCUSSIONS

### *Machine Animation*

The 3D animation of the various modes of movement of the machine was carried out. This was achieved with the aid of the Autodesk 3ds max animation software. The design stages of the animation process using the 3ds max software are as shown in Figure 5 for X, Y and Z axes respectively. The maximum machine movements for the simulated router are 600, 400 and 152.4 mm along the X, Y and Z axes respectively.



Figure 5: X, Y and Z- axis movement of the machine

The program of instructions, to interface the stepper motors with the microcontroller was written using the C programming language software. The Proteus software was used in the simulation of the machine's component based on the program of instructions encoded using the C language. Proteus is a piece of software used in simulation of microprocessors, printed circuit board design and schematic capture. Figure 6 shows the Proteus circuit simulation design.

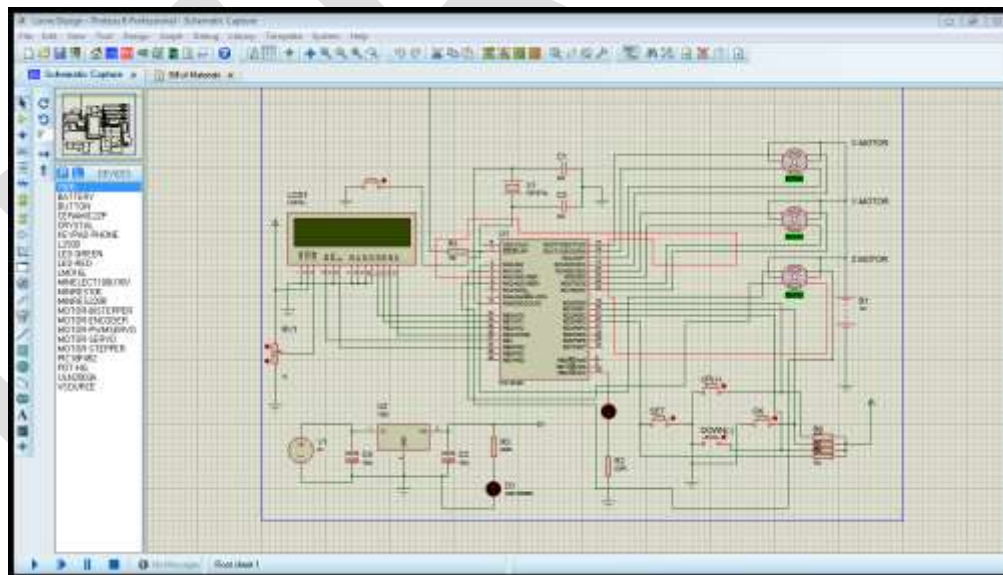

Figure 6: Snap shot of the Circuit Simulation Design using Proteus

The developed CNC router machine integrated with a microcontroller is designed for drilling operations (i.e. reaming, counter boring, countersinking etc). The microcontroller is an integral part of the system (i.e. the brain box for the machine). The programmed microcontroller enabled the CNC router to carry out specific operations. The ease of data input of the software enables the operator to input the coordinates of the axis with the aid of a keypad. Electric signals are sent to the microcontroller as soon as the coordinates are inputted using the keypad. This translates the electric signals to

positional movement along the X, Y and Z axes as the case may be with the aid of the stepper motors. The animation of the working principle of the CNC machine was developed using the Autodesk Inventor package.

### CONCLUSIONS AND RECOMMENDATIONS

The development a low cost CNC router machine described in this work, and to be adopted within the small scale industries, would increase the understanding of the machine development and strategy in Nigeria. It is anticipated that the designed CNC drilling router machine could bring about the resource efficiency of the small scale industries if adopted for drilling of holes on wood, light metals and plastics materials. The workability of the developed CNC drilling router machine is also exhibited on the result of the simulation obtained. The CNC router machine designed can be useful to those who are hobbyist and in the small tasks workshops. Further conclusions deduced from this work include:

1. The designed strategy can be adopted to increase the capacity of the CNC router machine. The machine can also be adopted for engraving tasks.
2. If the developed CNC router machine is integrated with a PC based controller (i.e. a PC controlled CNC software installed on it), it will have the capability to design and define the shapes that needs to be cut e.g. circles, rectangles, drill patterns etc.
3. A developed transfer function incorporated into the CNC router machine could aid the control of the spindle mechanisms.

### REFERENCES:

- [1] Bramble, K. (2007). Engineering design for manufacturing. Engineers edge, Monroe (GA).
- [2] Ryan, V. (2009), CNC work- an introduction retrieved from [www.technologystudent.com/.../cnc1\\_May\\_2013](http://www.technologystudent.com/.../cnc1_May_2013).
- [3] Schneider, G. (2002). Cutting Tool Applications. T & P: Tooling and production, 68(4), 14-23.
- [4] Groover, M.P. (2010), Fundamentals of Modern Manufacturing, Materials, Processes and System, International Editions, Prentice Hall, pp 50764
- [5] Balogun, V. A., Mativenga, P. T., (2014). Impact of un-deformed chip thickness on specific energy in mechanical machining processes, Journal of Cleaner Production 69: 260-268.
- [6] Kalpakjian, S., Schmid, S., 2003. Manufacturing Processes for Engineering Materials. Prentice-Hall, Englewood Cliffs, New Jersey.
- [7] Erdel, B. (2003), *High-speed machining*, SAE technical paper.
- [8] Patrick, C., Charles, C., Wesley, D., and Paul, J. (2011), *CNC Application and Design*, Worcester Polytechnic Institute, Worcester, Massachusetts, United States. pp 1-19
- [9] Yash, S. (2012), *History of Milling Machine* retrieved 20<sup>th</sup> of May 2013
- [10] Electronic Industries Association, (1992). ANSI/EIA-494-B-1992, 32 Bit Binary CL (BCL) and 7 Bit ASCII CL (ACL) Exchange Input Format for Numerically Controlled Machines. Washington, D.C.
- [11] Chen, Q., Chen, X., (2006). Application and development trend of CNC router. Journal of Harbin Bearing, 1, 024.
- [12] Onwubolu, G. C., Aborhey, S., Singh, R., Reddy, H., Prasad, M., Kumar, S., & Singh, S., (2002). Development of a PC-based computer numerical control drilling machine. Proceedings of the Institution of Mechanical Engineers, Part B: Journal of Engineering Manufacture, 216(11), 1509-1515.

- [13] Salihmuhsin, M., Baba, S., Yılmaz, A. S., & Sekkeli, M., (2015). Development of a Computer Controlled Automated PCB Machine. APJES III-II14-21, DOI: 10.5505/apjes.2015.83803.
- [14] Quental, N., Lourenço, J. M., da Silva, F. N. (2011). Sustainable development policy: goals, targets and political cycles. Sustainable Development, 19(1), 15-29.
- [15] Williams, N., Burry, J., Davis, D., Peters, B., de Leon, A. P., & Burry, M. (2015). FabPod: Designing with temporal flexibility & relationships to mass-customization. Automation in Construction, 51, 124-131.
- [16] Ashby.,Michael,F.,(2005), Materials Selection in Mechanical Design 3<sup>rd</sup> edition, Oxford: Elsevier, London, pp.23

IJERGS