

An Active Power Filter for Improving the Power Quality of a Distribution Grid

Anju R K¹, Fossy Mary Chacko²

PG Student, Dept. of EEE, Saintgits College of Engineering, Kottayam, Kerala, India¹

Assistant Professor, Dept. of EEE, Saintgits College of Engineering, Kottayam, Kerala, India²

Abstract— The electric power quality has become an important part of the distribution power system. The aim of this paper is to improve the power quality of the distribution grid. Here, an energy storage is integrated into dc-link of the Active Power Filter through a bidirectional dc-dc converter that helps in providing a stiff dc-link voltage. The integration helps in providing active/reactive power support, intermittency smoothing, and harmonic compensation. The design and control of both the dc-ac inverters and the dc-dc converter is also developed.

Keywords—Distributed Energy Resource (DER), Active Power Filter (APF), Power Conditioner (PC), Total Harmonic Distortion (THD), Distribution Grid (DG), Power Quality (PQ), Plug-in Hybrid Electric Vehicle(PHEV)

INTRODUCTION

PQ may be defined as a provision of voltages and a system design so that the user of electric power can utilize electric energy from the distribution system successfully, without interference on interruption [1]. Harmonics are the primary cause for the poor power quality of the distribution system. Harmonics are caused by non-linear loads i.e. loads that draw a non sinusoidal current from a sinusoidal voltage source. Some examples of harmonic producing loads are electric arc furnaces, static VAR compensators, inverters, DC converters, switch-mode power supplies, and AC or DC motor drives.

Renewable energy generation is growing fast and ideas such as smart grid are trying to change the role of a consumer from being a passive consumer to an active contributor who can supply stored excess power in various DERs, such as solar, wind and PHEVs back to the distribution grid or the micro-grid. Most of the DERs are intermittent and integrating them with energy storage not only improves the reliability of the DERs but also gives an opportunity to provide additional functionalities such as active and reactive power support and harmonic compensation to distribution grid. Of all the energy storage technologies Ultracapacitors (UCAP) have low energy density and high power density and fast charge/discharge characteristics[3, 5]. Therefore, they are ideally suited for providing support to events on the distribution grid which require high power and low energy for short spans of time. UCAPs also have higher number of charge-discharge cycles and higher terminal voltage per module when compared to batteries which again make them ideal choice for providing grid support for short time. UCAP based energy storage can be integrated into the distribution grid through a bi-directional dc-dc converter and a dc-ac inverter and this integration can be carried out by connecting the dc-ac inverter in shunt as an Active Power Filter (APF) with the grid.

SYSTEM CONFIGURATION

The one-line diagram of the system is shown in Figure 1. The system consists of a UCAP on the input side of the bi-directional dc-dc converter which acts as an interface between the UCAP and the 3-phase grid connected inverter. The major advantage of integrating the UCAP and the APF system is that the system now has the capability to supply and absorb Active Power from the grid [14]. A bi-directional dc-dc converter interface is necessary since the UCAP voltage profile changes as it charges/discharges energy while the inverter dc-link voltage has to stay constant for accurate control of inverter. Therefore, it acts as a boost converter while the UCAP is discharging energy into the grid and as a buck converter while charging the UCAP from the grid.

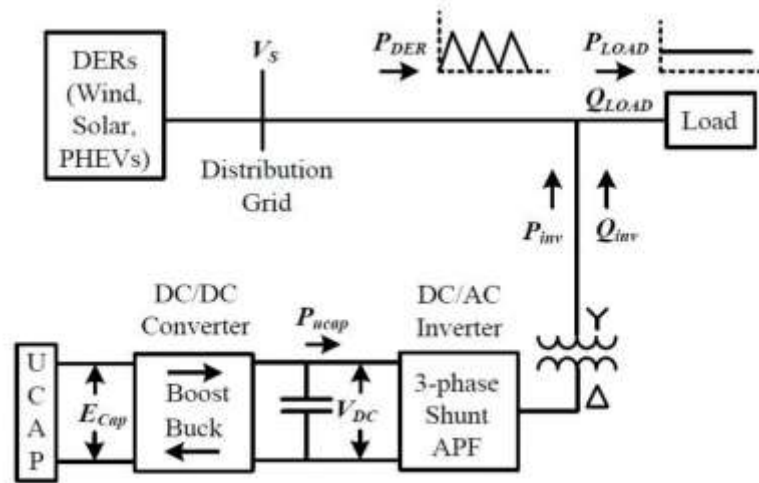

Fig 1. One line diagram of APF with UCAP energy storage

The complete circuit diagram of the shunt APF, and the bidirectional dc-dc converter is shown in Figure 2. The inverter systems consist of IGBT module, its gate-driver, LC filter, and an isolation transformer. The dc-link voltage, V_{dc} is regulated at 260 V for optimum voltage and current compensation of the converter and the line-line voltage, V_{ab} is 208 V.

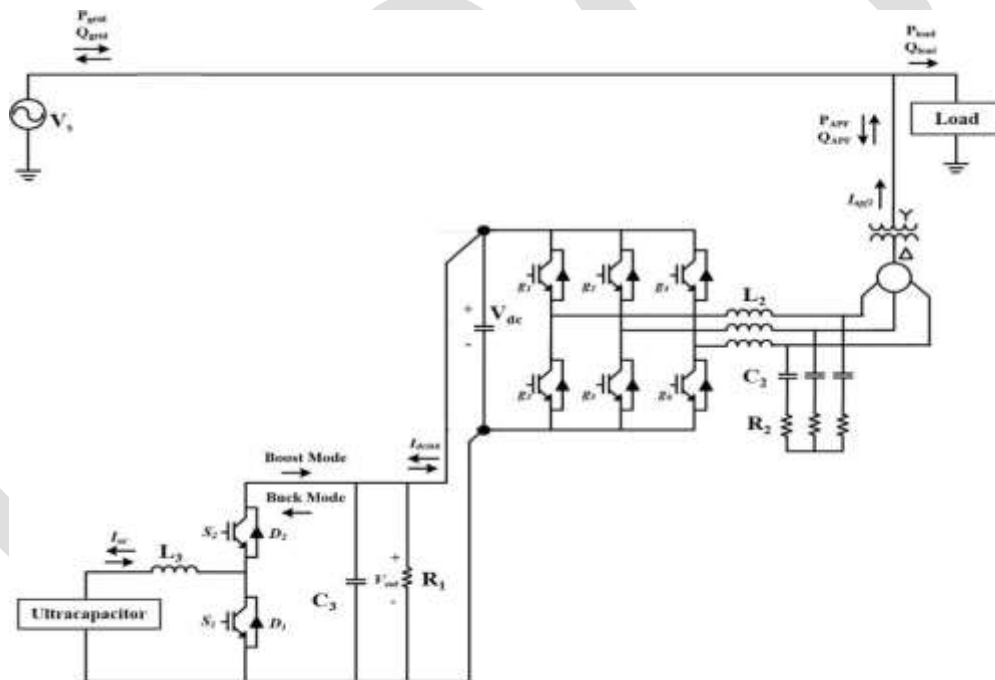

Fig 2. Model of APF with UCAP energy storage

There are various methods to control the 3-phase shunt APF to provide harmonic and reactive power compensation of which the most common approaches are the p-q method and the i_d - i_q method [2, 11]. The i_d - i_q control performs better in non-sinusoidal and unbalanced conditions when compared to the p-q method, while both methods perform in a similar manner in balanced sinusoidal conditions. In this system, the i_d - i_q method is modified to provide active and reactive power compensation such that i_d controls the reactive power and i_q controls the active power. Therefore, based on the references for active and reactive powers P_{ref} and Q_{ref} the reference currents i_{qref} and i_{dref} in d-q domain can be calculated using (2) and (4) where v_q is the system voltage in q-domain. Once the reference currents are calculated they are compared with the actual inverter currents and the error is passed through a PI controller.

$$P_{ref} = -\frac{3}{2}(V_q I_{qref} + V_d I_{dref}) \quad (1)$$

If $V_d=0$, then

$$P_{ref} = -\frac{3}{2}(V_q I_{qref}) \quad (2)$$

$$Q_{ref} = \frac{3}{2}(V_d I_{qref} - V_q I_{dref}) \quad (3)$$

If $V_d=0$, then

$$Q_{ref} = -\frac{3}{2}(V_q I_{dref}) \quad (4)$$

$$\begin{bmatrix} i_{refa} \\ i_{refb} \\ i_{refc} \end{bmatrix} = \begin{bmatrix} 1 & 0 \\ -\frac{1}{2} & \frac{\sqrt{3}}{2} \\ -\frac{1}{2} & -\frac{\sqrt{3}}{2} \end{bmatrix} \begin{bmatrix} \cos \theta & \sin \theta \\ -\sin \theta & \cos \theta \end{bmatrix} \begin{bmatrix} i_{dref} \\ i_{qref} \end{bmatrix} \quad (5)$$

The load currents are tracked upon which Park's transformation is performed to obtain corresponding d-q axes currents. According to i_d - i_q control strategy, only the average value of d-axis component of load current should be drawn from supply. Here the fundamental frequency component of d-q axes currents are separated i.e the oscillating components are filtered out using low-pass filter [10].

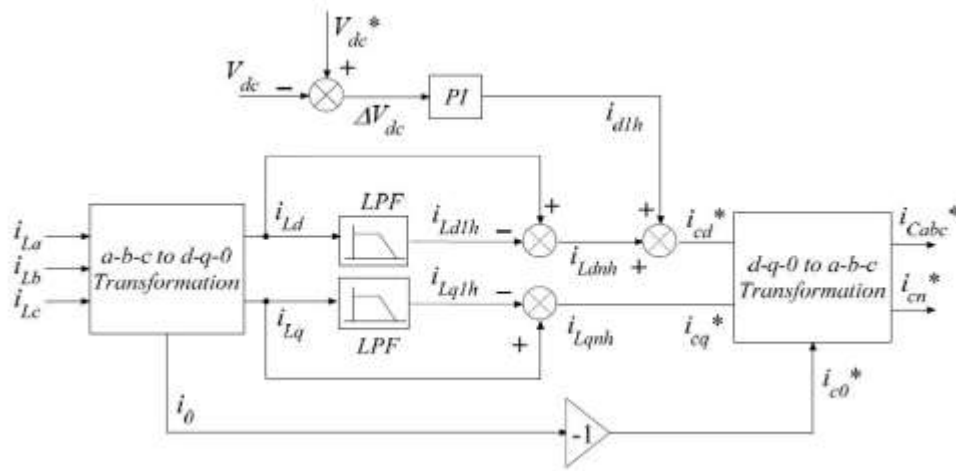

Fig 3. Reference current extraction with i_d - i_q method

These currents are utilized to generate reference filter currents in d-q coordinates, followed by inverse Park transformation giving away the compensation currents [8, 9]. Ultimately, the filter provides necessary compensation for harmonics in the source current, reactive power unbalance and active power support in the system.

BIDIRECTIONAL DC-DC CONVERTER

A bidirectional dc-dc converter [6] is required as an interface between the UCAP and the dc-link, since the UCAP voltage varies with the amount of energy discharged, while the dc-link voltage has to be stiff. The model of the bidirectional dc-dc converter is shown in Figure 4. The dc-dc converter should operate in Discharge mode, while providing active/reactive power support and voltage sag

compensation. The dc-dc converter should also be able to operate in bidirectional mode to be able to charge or absorb additional power from the grid during intermittency smoothing. In this paper, the bidirectional dc-dc converter acts as a boost converter while discharging power from the UCAP and acts as a buck converter while charging the UCAP from the grid.

Average current mode control [4, 13] is used to regulate the output voltage of the bidirectional dc-dc converter in both Buck and Boost modes, while charging and discharging the UCAP bank. While the UCAP-APF system is discharging power, the dc-link voltage V_{out} tends to be less than V_{ref} , which causes the reference current I_{ucref} to be positive, thereby operating the dc-dc converter in Boost mode. Along similar lines, when the UCAP-APF system is absorbing power from the grid, the dc-link voltage V_{out} tends to be greater than V_{ref} , which causes the reference current I_{ucref} to be negative and thereby operating the dc-dc converter in Buck mode. Average current mode control technique was found as the ideal method for UCAP-APF integration as it tends to be more stable when compared with other methods like voltage mode control and peak current mode control [12]. This is a major advantage in the present topology, where the stability of the dc-dc converter has to be ensured over a wide operating range and in both Buck and Boost modes of operation.

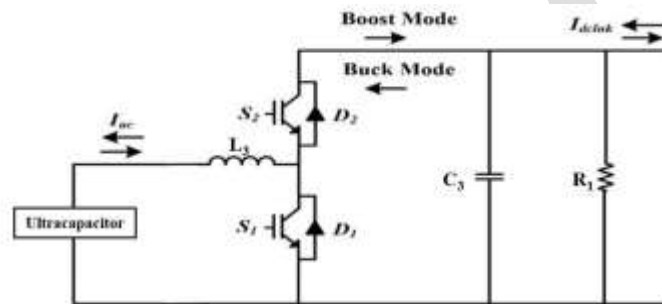

Fig 4. Model of bidirectional dc-dc converter

ULTRACAPACITORS

Ultracapacitors are a new technology that allows storing 20 times more energy than conventional electrolytic capacitors. Ultracapacitors are electrochemical double layer capacitors that have unique characteristics when compared to other energy storage devices. Ultracapacitors (UCAPs) have high energy density and large time constants as well. The benefits of using ultracapacitors are quite extensive. Ultracapacitors have low losses while charging and discharging. They have a very low ESR, allowing them to deliver and absorb very high currents and to be charged very quickly, making them well suited for energy buffer applications [7]. Ultracapacitors are highly efficient components even at very high currents. The characteristics of the UCAP allow it to be charged and discharged at the same rates, something most batteries cannot tolerate. Ultracapacitors have a wide voltage window and can be deeply discharged. The energy storage mechanism of an UCAP is a highly reversible process. The process moves charge and ions only. It does not make or break chemical bonds like batteries; therefore it is capable of millions of cycles with minimal change in performance. It is therefore capable of many years of continuous duty with minimal change in performance. These advantages make ultracapacitors well suited for power quality conditioning applications. Higher order ultracapacitor models are essential for simulation studies in which the timescale of interest is on the order of microseconds. In the current application, the timescale of interest is on the order of minutes; therefore the single RC branch model is sufficient to capture the UCAP behavior of interest.

MODES OF OPERATION

The different modes of operation of the APF are as described below:

1. Active Power Support Mode
2. Reactive Power Support Mode
3. Renewable Intermittency Smoothing Mode
4. Harmonic Compensation

1. Active Power Support Mode

In active power support mode, the APF must provide active power to the grid. Based on the reference value, P_{ref} , the APF supplies the active power. The dc-dc converter will operate in a bidirectional fashion in both Buck and Boost modes to respond to the active

power requests and regulate the dc-link voltage in a stable fashion, while the inverter controller should respond such that the commanded P_{ref} is supplied by the inverter through current control.

2. Renewable Intermittency Smoothing Mode

In Renewable Intermittency Smoothing Mode, the APF must be capable of both supplying and absorbing active power. The dc-dc converter will operate in a bidirectional fashion in both Buck and Boost mode to regulate the dc-link voltage in a stable fashion, while the inverter controller should respond such that the commanded P_{ref} is supplied/absorbed through the inverter current control.

3. Reactive Power Support Mode

In reactive power support mode, the APF must provide reactive power to the grid. In this mode, the APF does not provide any active power to the grid and even the APF losses are supplied by the grid. Based on the reference Q_{ref} , the power conditioner supplies the reactive power. The goal of the dc-dc converter controller is to regulate the dc-link voltage in a stable fashion, while the inverter controller should respond such that the commanded Q_{ref} is supplied by the inverter through current control.

4. Harmonic Compensation

The APF is controlled to eliminate the harmonics caused by non-linear load connected to the network. The controller maintains the THD well within the IEEE-519 standards.

SIMULATIONS AND RESULT

The proposed model is implemented in MATLAB/Simulink. The simulated model is as shown in figure 5. The simulation parameters are as listed in Table I.

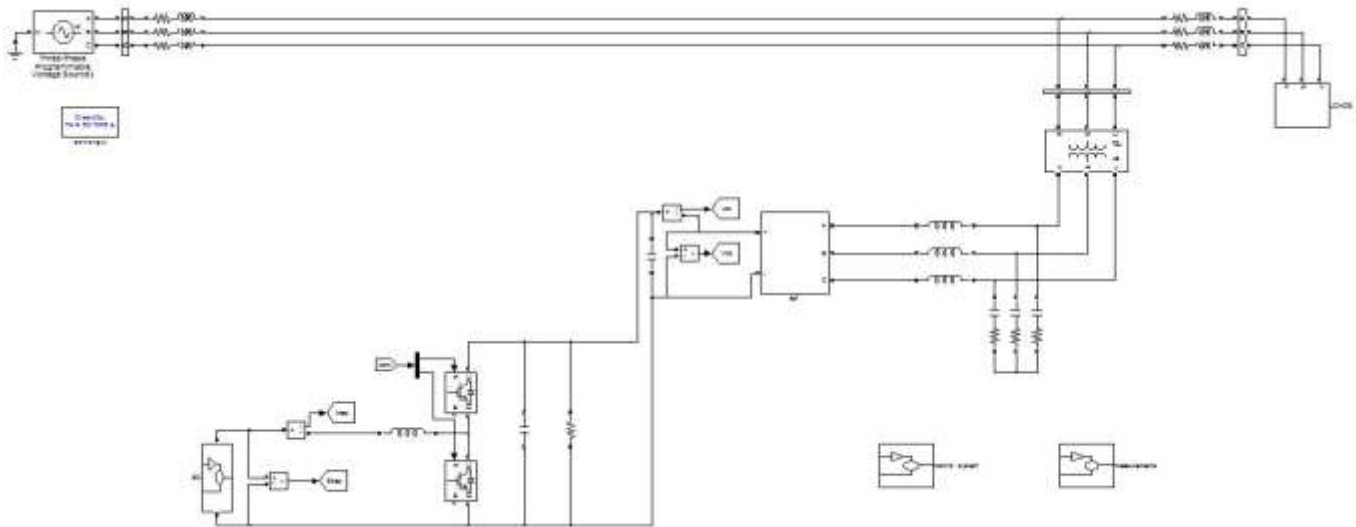

Fig 5. MATLAB/Simulink model of the APF

Table I. Simulation Parameters

Parameter	Values
Source Voltage	0.208kV
Inverter Component	IGBT based
DC Link Voltage	$V_{dc}=260$ V
DC Link Capacitor	$C_{dc}=3500$ μ F
Load	Three phase non-linear RL load $P_{load} = 1000$ W $Q_{load} = 4.0$ kVar

The simulation of the complete system which includes the 3-phase grid tied inverter and the dc-dc converter is performed using

MATLAB. The ability of the system to supply commanded active power is simulated with $i_{qref} = -12.0A$ which translates to P_{ref} of 3054 W. The simulation results are shown in Figure 6(a) and Figure 6(b) where it can be observed that P_{inv} have converged to steady state values closely tracking the commanded P_{ref} .

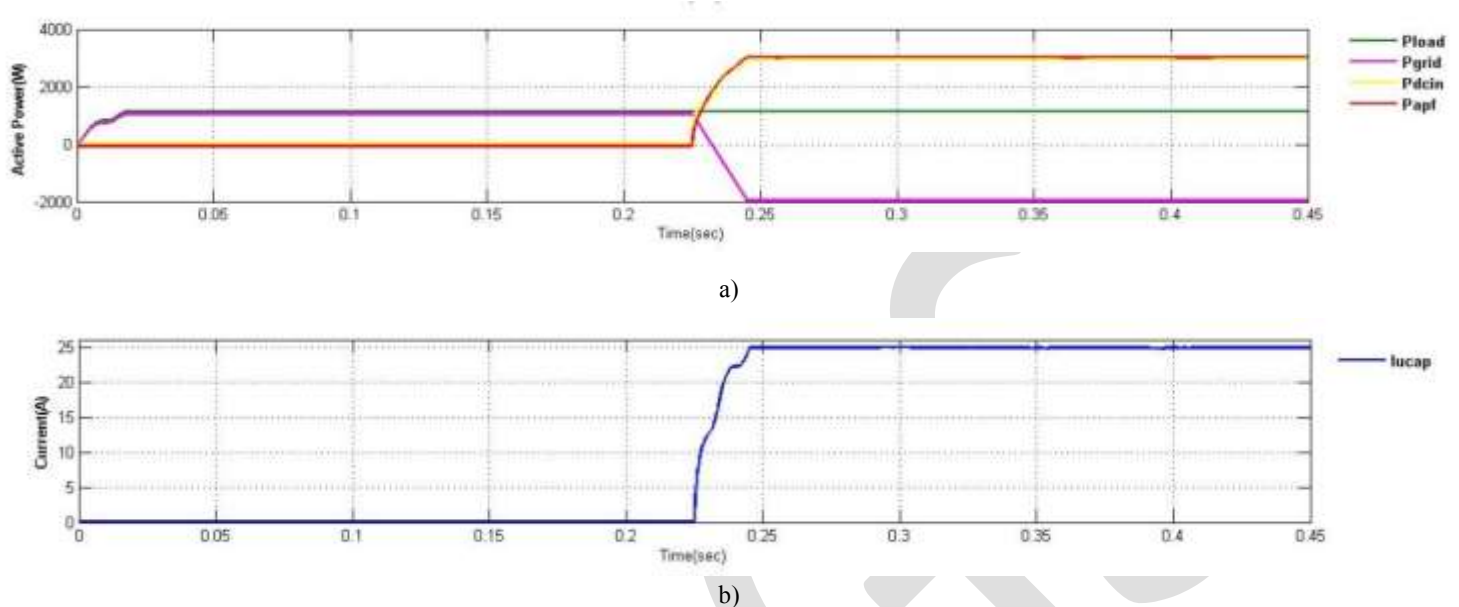

Fig 6. a) Grid, load and inverter active power curves for $i_{qref} = -12.0A$ (active power support) b) UCAP current

The ability of the system to supply the reactive power requirement of the load is simulated with a Q_{ref} of 4000Var. The simulation setup is the same as in the previous case and the simulation results are shown in Figure 7(a) and Figure 7(b). It can be observed that Q_{inv} have converged to the steady state values closely tracking Q_{ref} .

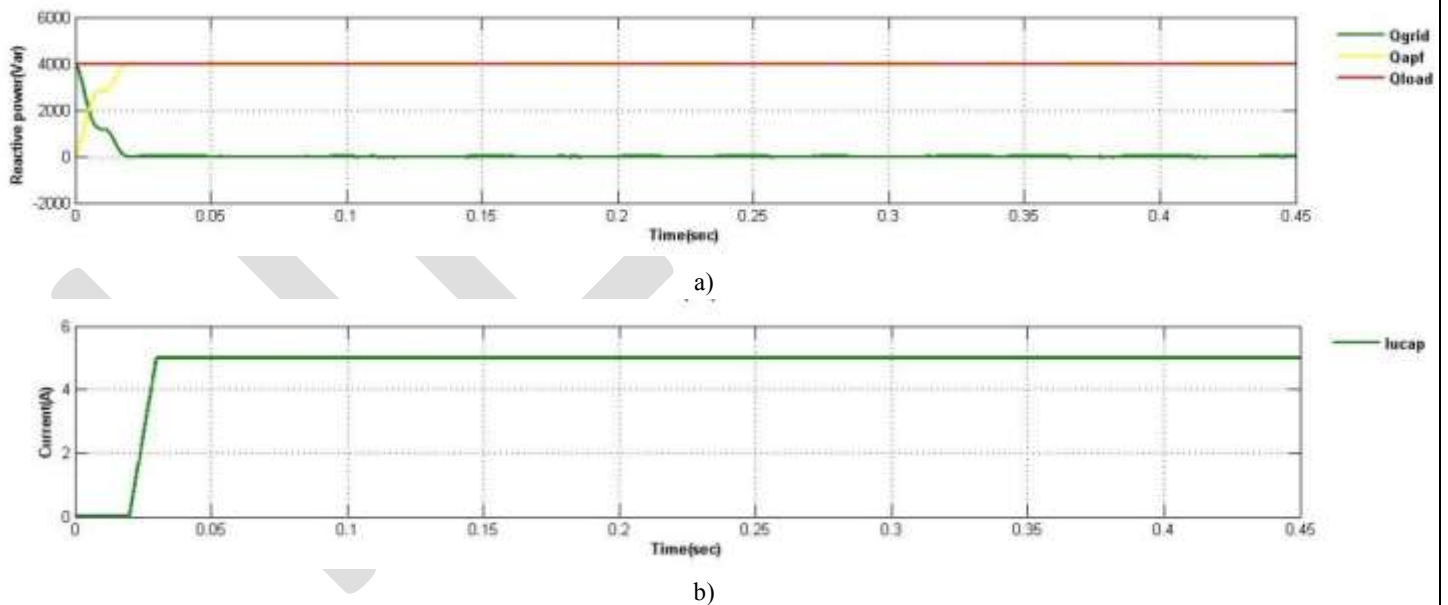

Fig 7. a) Grid, load and inverter reactive power curves (reactive power support) b) UCAP current

The simulation results for the renewable intermittency smoothing applications where the PC must be capable of both supplying and absorbing active power are illustrated. Since the results for the case where the UCAP and the inverter system supply active power to the grid are already presented in Figure 6 so in Figure 8(a) and Figure 8(b) similar results are presented for the case where the UCAP and inverter system absorb active power from the grid which is achieved by commanding a positive i_{qref} of 7A which corresponds to a P_{ref} of -1782W. It can be observed that P_{inv} have converged to steady state values tracking the commanded P_{ref} closely.

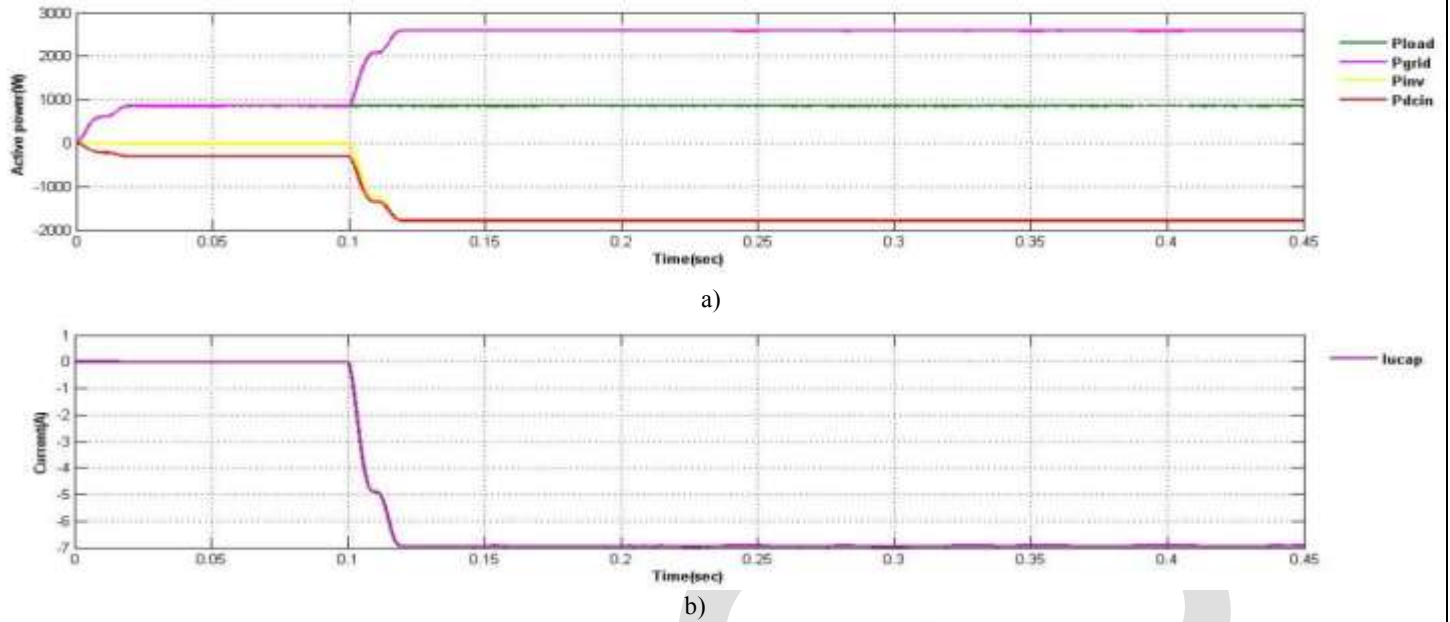

Fig 8. a) Grid, load and inverter active power curves for $i_{qref} = 7.0A$ (renewable intermittency smoothing; absorbing active power) b) UCAP current

The supply current without APF contains harmonic components. With the insertion of APF the THD of the grid current is reduced from 29.15% to 2.64%. Figure 9(a), Figure 9(b) and Figure 9(c) shows the single phase source current, load current and compensating current. The DC link voltage V_{dc} is as shown in Figure 10 and it can be seen that the voltage is maintained at a constant value of 260V.

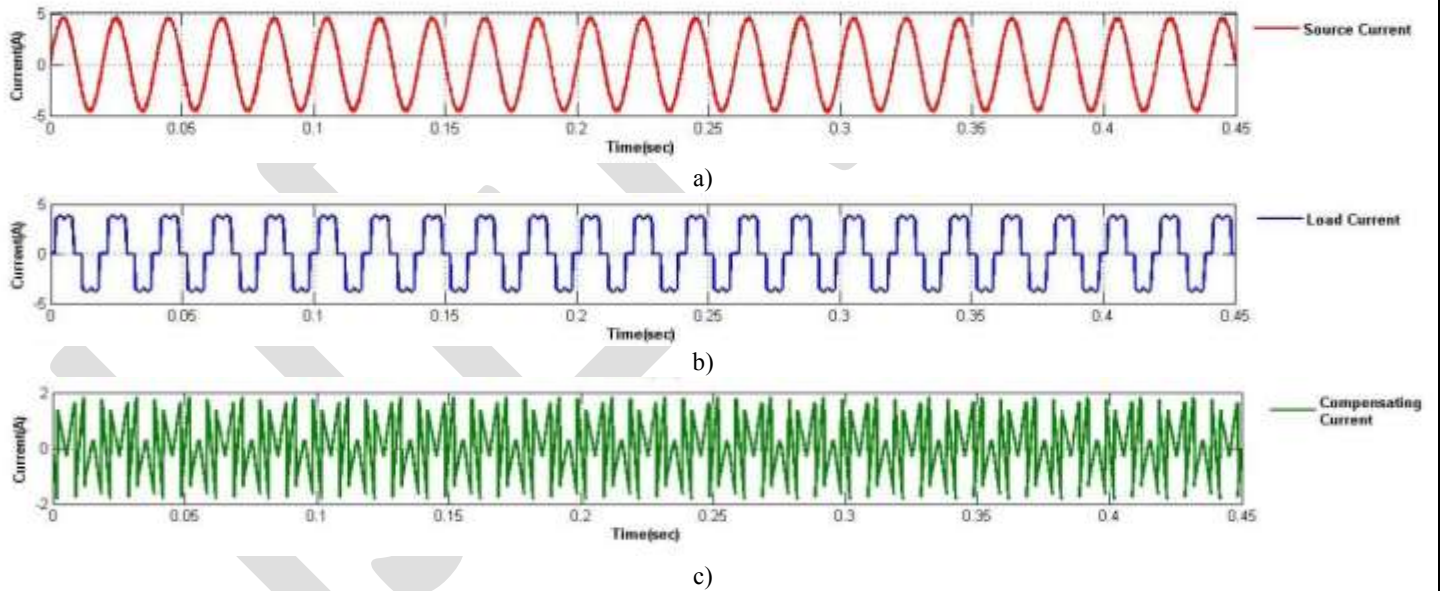

Fig 9. a) Single Phase source current b) Single Phase load current c) Single Phase compensating current

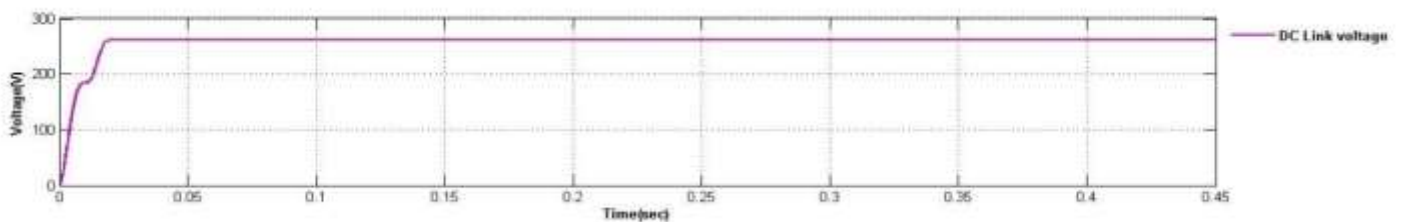

Fig10. DC Link Voltage

Therefore, it is evident from the simulations that the UCAP and APF system can together provide active and reactive power support to the grid. It is also evident that both the dc-dc converter and inverter can operate in a bi-directional fashion which is necessary when the system is used in renewable intermittency smoothing applications. Active power support, reactive power support, renewable intermittency smoothing and harmonic compensation are the primary functionalities the UCAP integrated APF system will be providing to the distribution grid.

CONCLUSION

Renewable intermittency smoothing is one application that requires active power support from energy storage in the seconds to minutes time scale. By incorporating an Active Power Filter with adequate energy storage, the power quality of the distribution grid is improved. In this paper, a power conditioner system to improve the power quality of the distribution grid is presented. With this integration of suitable energy storage the APF will be able to provide active/reactive power support, renewable intermittency smoothing and harmonic compensation to the distribution grid. This cannot be achieved by a conventional APF with dc-link capacitor which does not have active power capability and thus provides additional functionalities on comparing with an UPQC. The proposed APF was simulated with a PI controller. Average current mode control is used to regulate the output voltage of the dc-dc converter due to its inherently stable characteristic. The simulation of the proposed model is carried out using MATLAB.

REFERENCES:

- [1] E.F. Fuchs and M.A.S. Masoum, "Power Quality in Electrical Machines and Power Systems", Elsevier, Academic Press, USA, Feb. 2008 (ISBN- 13: 978-0-12-369536-9).
- [2] V. Soares, P. Verdelho, and G. D. Marques, "An Instantaneous Active and Reactive current component method for active filters," IEEE Trans. Power Electron., vol. 15, no. 4, pp. 660-669, Jul. 2000.
- [3] K. Sahay and B. Dwivedi, "Supercapacitors energy storage system for power quality improvement: An overview," J. Energy Sources, vol. 10, no. 10, pp. 1-8, 2009.
- [4] C. Philip, "Modeling average current mode control [of power converters]," in Proc. IEEE Applied Power Electronics Conference and Exposition, Feb. 2000, pp. 256-262.
- [5] P. F. Ribeiro, B. K. Johnson, M. L. Crow, A. Arsoy, and Y. Liu, "Energy storage systems for advanced power applications," Proc. IEEE, vol. 89, no. 12, pp. 1744- 1756, Dec. 2001.
- [6] ArchanaBhat, "Analysis of Ripple Content in DC-DC Converters", International Journal of Inventive Engineering and Sciences (IJIES) ISSN: 2319-9598, Volume-1, Issue-7, June 2013.
- [7] W. Li, G. Joos, and J. Belanger, "Real-time simulation of a wind turbine generator coupled with a battery supercapacitor energy storage system," IEEE Trans. Ind. Electron., vol. 57, no. 4, pp. 1137-1145, Apr. 2010.
- [8] S. Bhattacharya, D.M. Divan, T.M. Frank, and B. Banerjee, "Active filter system implementation," IEEE Ind. Appl. Mag., vol. 4, no. 5, pp. 47-63, Sep./Oct. 1998.
- [9] Rejil C, Anzari M, Arun Kumar R, "Design and Simulation of Three Phase Shunt Active Power Filter Using SRF Theory", Advance in Electronic and Electric Engineering. ISSN 2231-1297, Volume 3, Number 6 (2013), pp. 651-660.
- [10] Chennai Salim, Benchouia Mohamed Toufik, "Intelligent Controllers for Shunt Active Filter to Compensate Current Harmonics Based on SRF and SCR Control Strategies", International Journal on Electrical Engineering and Informatics - Volume 3, Number 3, 2011.
- [11] Maria Isabel Milanes Montero, Enrique Romero Cadaval, Fermin Barrero Gonzalez, " Comparison of Control Strategies for Shunt Active Power Filters in Three-Phase Four-Wire Systems", IEEE Transactions on Power Electronics, vol. 22, no. 1, January 2007.
- [12] K. Wan, J. Liao, and M. Ferdowsi, "Control methods in dc-dc power conversion – a comparative study," in Proc. Power Electronics Specialists Conference, Jun. 2007, pp. 921-926.
- [13] K. Wan and M. Ferdowsi, "Projected Cross Point – a new average current-mode control approach," in Proc. IEEE Applied Power Electronics Conference and Exposition, Austin, Texas, Feb. 2008.
- [14] Deepak Somayajula, Mariesa L. Crow, "An Integrated Active Power Filter–Ultracapacitor Design to Provide Intermittency Smoothing and Reactive Power Support to the Distribution Grid", IEEE Transactions on Sustainable Energy, vol. 5, no. 4, October 2014.