

# INCREASING THE POWER SYSTEM SWITCH GEAR CAPACITY BY USING SUPERCONDUCTING FAULT CURRENT LIMITER

Rajesh Velpula

Department of Electrical & Electronics Engineering  
PSCMR College of Engineering & Technology

**ABSTRACT-** Superconducting fault-current limiters (SFCLs) have been the subject of research and development for many years and offer an attractive solution to the problem of rising fault levels in electrical distribution systems. SFCLs can greatly reduce fault currents and the damage at the point of fault, and help improve the stability of a power system. The resistance of an SFCL should be chosen to limit fault currents as much as possible. Not only does this benefit an electrical system through reduction in the potentially damaging effects of high fault currents, which is the primary purpose of the SFCL, but increasing the limitation of fault currents also has a consequence of shortening the recovery time of the SFCL by reducing the energy dissipated in the resistance of the SFCL. Superconducting fault-current limiters (SFCL) provide a new efficient approach to the reliable handling of such faults. (SFCLs) can be used for various nominal voltages and currents, and can be adapted to particular limiting characteristics in case of short circuits. Electrical equipment that controls high fault currents can increase the security of the network and allow power equipment to be designed more cost effectively. SFCL allows electrical interconnections of existing systems, which would not be possible without limiters. Finally, the SFCL is introduced in the higher capacity system. Thus, it is revealed that the outstanding current limiting performance of SFCL can be used to limit the fault to the level of the existing switchgear.

**Key words:** SFCL, Switch Gear, Stability, Fault Current, Circuit Breaker.

## I. INTRODUCTION

Electric power systems are designed such that the impedances between generation sources and loads are relatively low. This configuration assists in maintenance of a stable, fixed system voltage in which the current fluctuates to accommodate system loads. The primary advantage of this arrangement is that loads are practically independent of each other, which allows the system to operate stably when loads change. However, significant drawback of the low interconnection impedance is that large fault currents (5 to 20 times nominal) can develop during power system disturbances. In addition, the maximum fault current in a system tends to increase over time for a variety of reasons, including:

- Electric power demand increases (load growth) and subsequent increase in generation.
- Parallel conducting paths are added to accommodate load growth.
- Interconnections within the grid increase.
- Sources of distributed generation are added to an already complex system.

In an effort to prevent damage to existing power-system equipment and to reduce customer downtime, protection engineers and utility planners have developed elaborate schemes to detect fault currents and activate isolation devices (circuit breakers) that interrupt the over-current sufficiently rapidly to avoid damage to parts of the power grid. While these traditional protection methods are effective, the ever-increasing levels of fault current will soon exceed the interruption capabilities of existing devices. Shunt reactors (inductors) are used in many cases to decrease fault current. These devices have fixed impedance so they introduce a continuous load, which reduces system efficiency and in some cases can impair system stability. Fault current limiters (FCLs) and fault current controllers (FCCs) with the capability of rapidly increasing their impedance, and thus limiting high fault currents are being developed. These devices have the promise of controlling fault currents to levels where conventional protection equipment can operate safely. A significant advantage of proposed FCL technologies is the ability to remain virtually invisible to the grid under nominal operation, introducing negligible impedance in the power system until a fault event occurs. Ideally, once the limiting action is no longer needed, an FCL quickly returns to its nominal low impedance state.

Superconducting fault current limiters (SFCLs) utilize superconducting materials to limit the current directly or to supply a DC bias current that affects the level of magnetization of a saturable iron core. While many FCL design concepts are being evaluated for commercial use, improvements in superconducting materials over the last 20 years have driven the technology to the forefront. Case in point, the discovery of high-temperature superconductivity (HTS) in 1986 drastically improved the potential for economic operation of many superconducting devices. This improvement is due to the ability of HTS materials to operate at temperatures around 70K instead of near 4K, which is required by conventional superconductors.

## II. SUPERCONDUCTING FAULT CURRENT LIMITERS (SFCL)

### 2.1 FAULT-CURRENT PROBLEM

Electric power system designers often face fault-current problems when expanding existing buses. Larger transformers result in higher fault-duty levels, forcing the replacement of existing bus work and switchgear not rated for the new fault duty. Alternatively, the existing bus can be broken and served by two or more smaller transformers. Another alternative is use of a single, large, high-impedance transformer, resulting in degraded voltage regulation for all the customers on the bus. The classic tradeoff between fault control, bus capacity, and system stiffness has persisted for decades.

Other common system changes can result in a fault control problem:

- i) In some areas, such as the United States, additional generation from co generators and independent power producers (IPPs) raises the fault duty throughout a system
- ii) older but still operational equipment gradually becomes underrated through system growth; some equipment, such as transformers in underground vaults or cables, can be very expensive to replace
- iii) Customers request parallel services that enhance the reliability of their supply but raise the fault duty.

### 2.2 BASICS OF SFCL

Superconducting fault current limiter is a promising technique to limit fault current in power system. Normally non-linear characteristic of superconductor is used in SFCL to limit fault current. In a normal operating condition SFCL has no influence on the system due to the virtually zero resistance below its critical current in superconductors. But when system goes to abnormal condition due to the occurrence of a fault, current exceeds the critical value of superconductors resulting in the SFCL to go resistive state. This capability of SFCL to go off a finite resistive value state from zero resistance can be used to limit fault current. Different types of SFCLs have been developed until now. Many models for SFCL have been designed as resistor-type, reactor-type, and transformer-type etc. In this project a resistive-type SFCL is modeled using simulink. Quench and recovery characteristics are designed. An impedance of SFCL according to time  $t$  is expressed by (3.1)

$$R_{SFCL} = \begin{cases} 0, & (t_0 > t) \\ R_m \left[ 1 - \exp\left(-\frac{t-t_0}{T_{sc}}\right) \right]^{\frac{1}{2}}, & (t_0 \leq t < t_1) \\ a_1(t-t_1) + b_1, & (t_1 \leq t < t_2) \\ a_2(t-t_2) + b_2, & (t_2 \leq t) \end{cases}$$

Where  $R_m$  is the maximum resistance of the SFCL in the quenching state,  $T_{sc}$  is the time constant of the SFCL during transition from the superconducting state to the normal state.

Furthermore,  $t_0$  is the time to start the quenching. Finally,  $t_1$  and  $t_2$  are the first and second recovery times, respectively. Quenching and recovery characteristics of the SFCL modelled by MATLAB using (3.1) are shown in Fig. 3.1. In normal condition impedance of SFCL is zero which is shown in Fig. 3.1. Quenching process of SFCL start at  $t=1s$  due to the occurrence of fault causing impedance rises to its maximum value. Impedance again becomes zero after the fault clears.

### 2.3 SUPERCONDUCTIVE FCL

Superconductors offer a way to break through system design constraints by presenting impedance to the electrical system that varies depending on operating conditions. Superconducting fault-current limiters normally operate with low impedance and are "invisible" components in the electrical system. In the event of a fault, the limiter inserts impedance into the circuit and limits the fault current. With current limiters, the utility can provide a low-impedance, stiff system with a low fault-current level, as Fig. 2.1 shows.

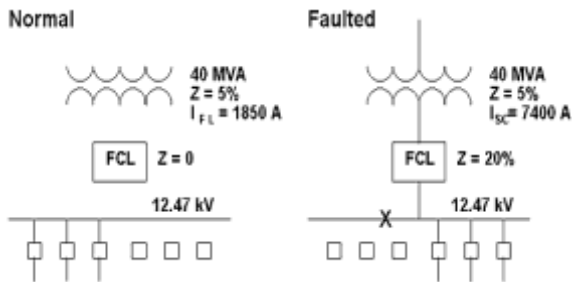

Fig. 2.1 Fault control with a fault-current limiter.

In Fig. 2.1, a large, low-impedance transformer is used to feed a bus. Normally, the FCL does not affect the circuit. In the event of a fault, the limiter develops an impedance of 0.2 per unit ( $Z = 20\%$ ), and the fault current  $I_{SC}$  is reduced to 7,400 A. Without the limiter, the fault current would be 37,000 A.

The development of high temperature superconductors (HTS) enables the development of economical fault-current limiters. Superconducting fault-current limiters were first studied over twenty years ago. The earliest designs used low temperature superconductors (LTS), materials that lose all resistance at temperatures a few degrees above absolute zero. LTS materials are generally cooled with liquid helium, a substance both expensive and difficult to handle. The discovery in 1986 of high temperature superconductors, which operate at higher temperatures and can be cooled by relatively inexpensive liquid nitrogen, renewed interest in superconducting fault-current limiters.

#### 2.4 STRUCTURE AND FUNCTIONAL PRINCIPLE OF THE FCL

The FCL, shown in Figure 2.2, is directly installed in the transformers neutral terminal. The FCL consists of a six-pulse thyristor rectifier (T1 to T6), a diode valve branch (V7 and V8), a freewheeling arm and an ohmic-inductive arm represented by  $R_d$  and  $L_d$ .

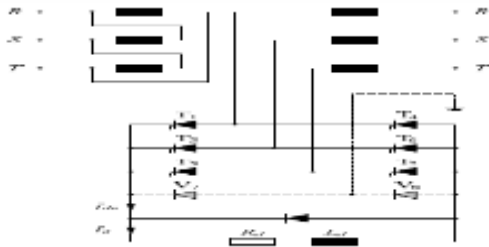

Fig 2.2 Fault Current Limiter (FCL) on a Diii-transformer

In case of no fault the thyristors are fired in their natural firing point and they behave like diodes in principle. Only in case of a fault the firing angle will be changed and the short circuit current will be limited actively. The inductance  $L_d$  will limit the rise of the short-circuit current. If the voltage across the choke falls under the threshold voltage of the diode, the freewheeling arm becomes active. In steady-state mode the currents in the FCL are not distorted. For controlling the short-circuit current only the behaviour in fault case will be discussed here. In fault case the currents will rise very fast, what directly induces the d.c current to rise very fast too? The whole d.c current has to flow through the coil and depending on its size it will convert to the steady state value with or without an overshoot. The task of the controller is to limit the possible overshoot on the one hand, as well as controlling the short-circuit current to a certain steady state value on the other hand. In fault case, the FCL operates in basically six operation modes.

These operation modes are commutation with a conducting freewheeling diode, commutation with a blocking freewheeling diode, two conducting thyristor valves at a blocking freewheeling diode, two conductive thyristors with a conducting freewheeling diode, intermittent d.c flow with a blocking freewheeling diode and intermittent d.c flow with a conducting freewheeling diode. For each state a mathematical description can be obtained by transforming the circuit into the state of the space phasor and solving the appropriate differential equations. For these mathematical transformations, in freewheeling case, the diode can be replaced by a voltage source in series with a resistor; whereby the voltage source is equivalent to the threshold voltage of the diode and the resistor describes the internal resistance of the diode. Once the freewheeling diode is blocking, it can be neglected..

**2.5 Types of Superconducting Fault Current Limiters (SFCL) :** The current limiting behaviour of SFCL depends on the nonlinear response of superconducting materials to temperature, current, and magnetic fields. Increasing any of these three parameters can cause a transition between superconducting and normal (resistive) conducting modes. SFCLs mainly have four categories.

- a. Resistive type SFCL
- b. Rectifier type SFCL
- c. Shielded iron-core type SFCL
- d. Saturated iron-core type SFCL

### III. SIMULATION MODELS & RESULTS

#### 3.1 SIMULATION MODEL OF SINGLE PHASE SYSTEM WITHOUT SFCL

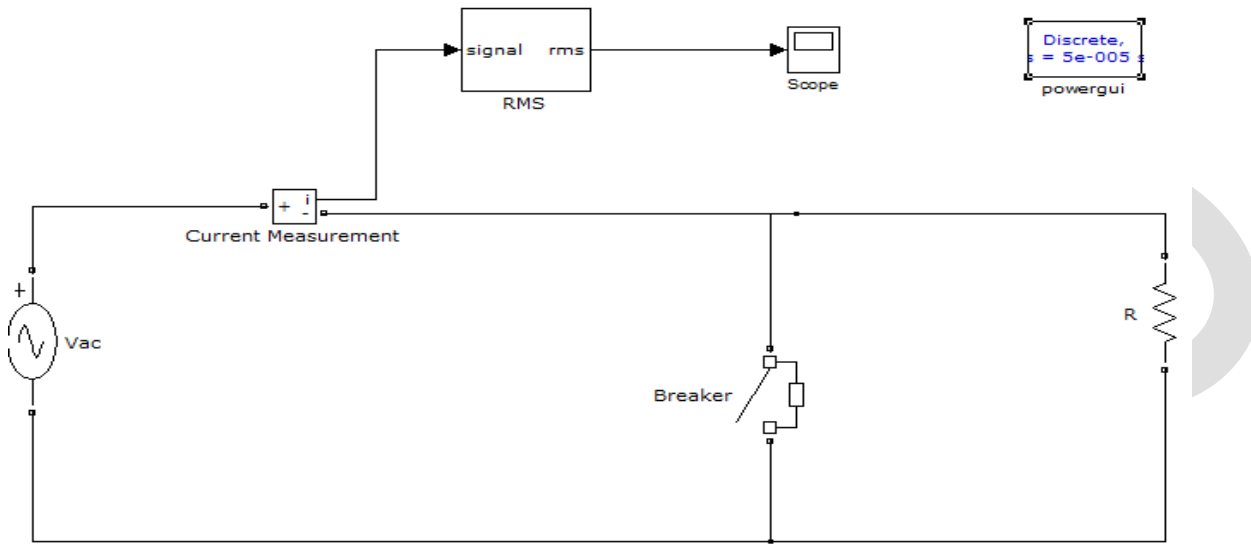

#### 3.2 SIMULATION MODEL OF SINGLE PHASE SYSTEM WITH SFCL

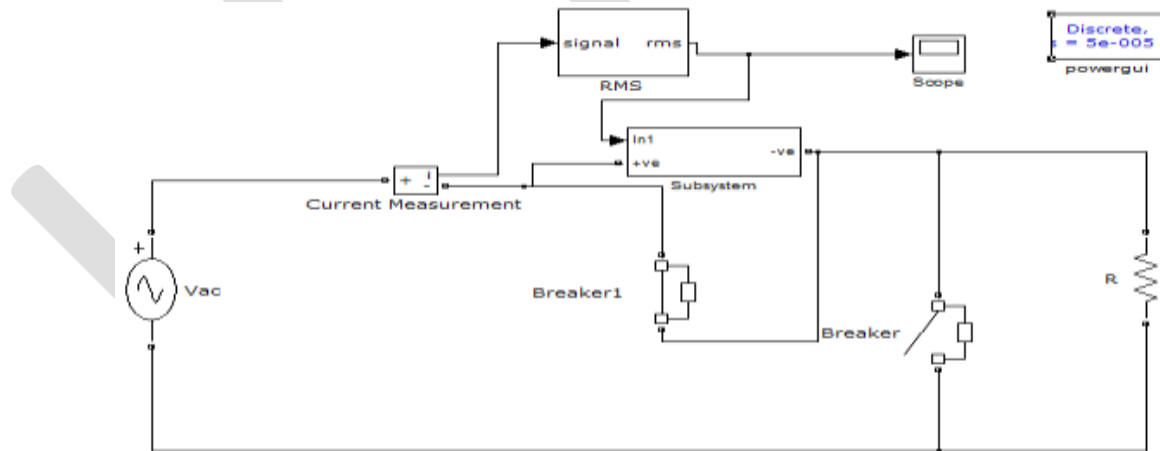

#### 3.3 SIMULATION MODEL OF 110MW SYSTEM WITHOUT SFCL

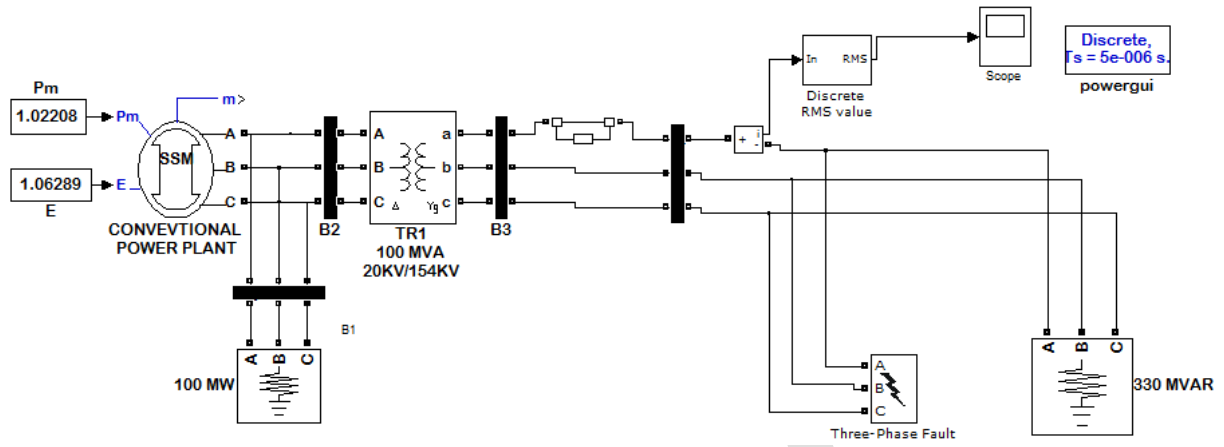

### 3.4 Simulated fault current waveforms with and without SFCL

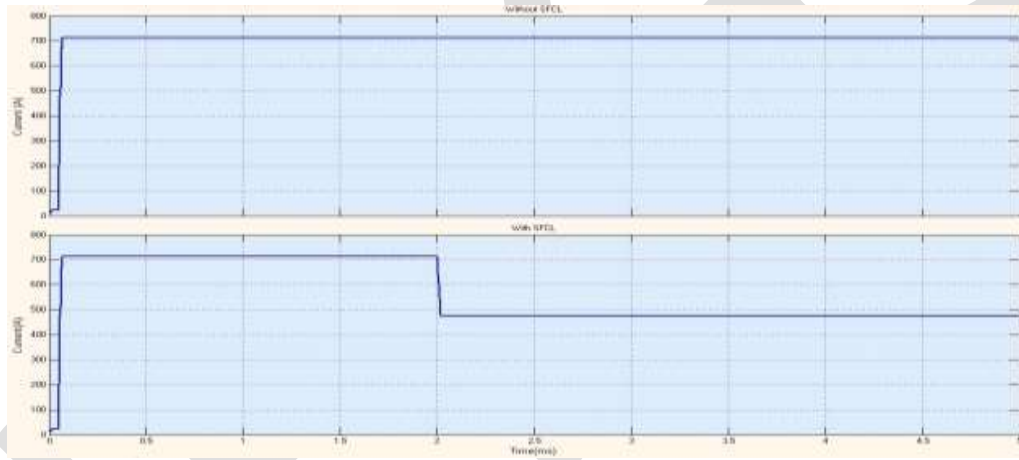

### 3.5 Simulated fault current waveforms for 110MW system in phase A

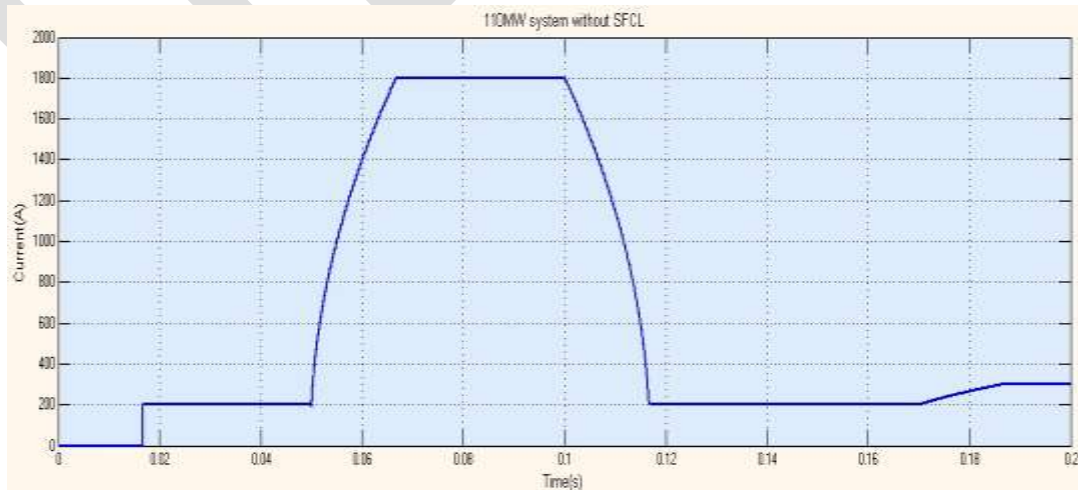

#### IV. CONCLUSION

This paper has proposed a study to increase the capacity of a power system by SFCL without changing the existing protective devices. The fault current 2700A of bigger system has been decreased to 1800A, in the range of smaller system, due to the use of SFCL. It is clear from the results that this inventive current limiting device is very efficient to decrease the fault current level significantly to the previous switchgear level. But coordination between the existing switchgear and SFCL is necessarily important for the practical application of this system. Otherwise it causes great hamper in the operation of protective devices which may results to get out of their original setting values. Thus, effective coordination between SFCL and existing protecting device will make it more successful in practical application issue. This coordination work may be the future issue.

#### REFERENCES:

- [1] Hye-Rim Kim, Seong-Eun Yang, Seung-Duck Yu, Heesun Kim, WooSeok Kim, KijunPark, Ok-BaeHyun, Byeong-Mo Yang, JungwookSim, and Young-Geun Kim, "Installation and Testing of SFCLs," IEEE Trans. Appl. Supercond , vol. 22, no. 3, June 2012.
- [2] M. Firouzi, G.B.Gharehpetian, and M. Pishvaie, "Proposed New Structure for Fault Current Limiting and Power Quality Improving Functions," International Conference on Renewable Energies and Power Quality (ICREPQ'10) Granada (Spain), 23rd to 25th March, 2010.
- [3] M. T. Hagh and M. Abapour, "Non superconducting Fault Current Limiter With Controlling the Magnitudes of Fault Currents," IEEE Trans. Power Electronics, Vol.24, PP. 613–619, March 2009.
- [4] Steven M. Blair, Campbell D. Booth, Nand K. Singh, and Graeme M. Burt, "Analysis of Energy Dissipation in Resistive Superconducting Fault-Current Limiters for Optimal Power System Performance," IEEE Trans. Appl. Supercond , vol. 21, no. 4, August 2011.
- [5] A. S. Emhemed, R. M. Tumilty, N. K. Singh, G. M. Burt, and J. R. McDonald, "Analysis of transient stability enhancement of LV connected induction micro generators by using resistive-type fault current limiters," IEEE Trans. Power Syst., vol. 25, no. 2, pp. 885–893, May 2010.
- [6] Gum Tae Son, Hee-Jin Lee, Soo-Young Lee, and Jung-Wook Park, "A Study on the Direct Stability Analysis of Multi-Machine Power System With Resistive SFCL," IEEE Trans. Appl. Supercond , vol. 22, no. 3, June 2012.
- [7] Jin-Seok Kim, Sung-Hun Lim, and Jae-Chul Kim, "Study on Application Method of Superconducting Fault Current Limiter for Protection Coordination of Protective Devices in a Power Distribution System," IEEE Trans. Appl. Supercond , vol. 22, no. 3, June 2012.
- [8] B. C. Sung, D. K. Park, J.-W. Park, and T. K. Ko, "Study on optimal location of a resistive SFCL applied to an electric power grid," IEEE Trans. Appl. Supercond., vol. 19, no. 3, pp. 2048–2052, June 2009.
- [9] S. M. Blair, C. D. Booth, I. M. Elders, N. K. Singh, G. M. Burt, and J. McCarthy, "Superconducting fault current limiter application in a power-dense marine electrical system," IET Elect. Syst. Transp., vol.1, no. 3, pp. 93–102, Sep. 2011.
- [10] MathiasNoe, AchimHobl, Pascal Tixador, Luciano Martini, and Bertrand Dutoit, "Conceptual Design of a 24 kV, 1 kA ResistiveSuperconducting Fault Current Limiter," IEEE Trans. Appl. Supercond , vol. 22, no. 3, June 2012.
- [11] Jin Bae Na, Young Jae Kim, Jae Young Jang, Kang SikRyu, Young Jin Hwang, Sukjin Choi, and Tae KukKo, "Design and Tests of PrototypHybridSuperconducting Fault Current Limiter With Fast Switch," IEEE Trans. Appl. Supercond , vol. 22, no. 3, June 2012.